

Reliable  
& Smart™

# NMC Series

EtherCAT-based High Performance  
Motion Controller

EtherCAT®

NMC: Network Motion Controller

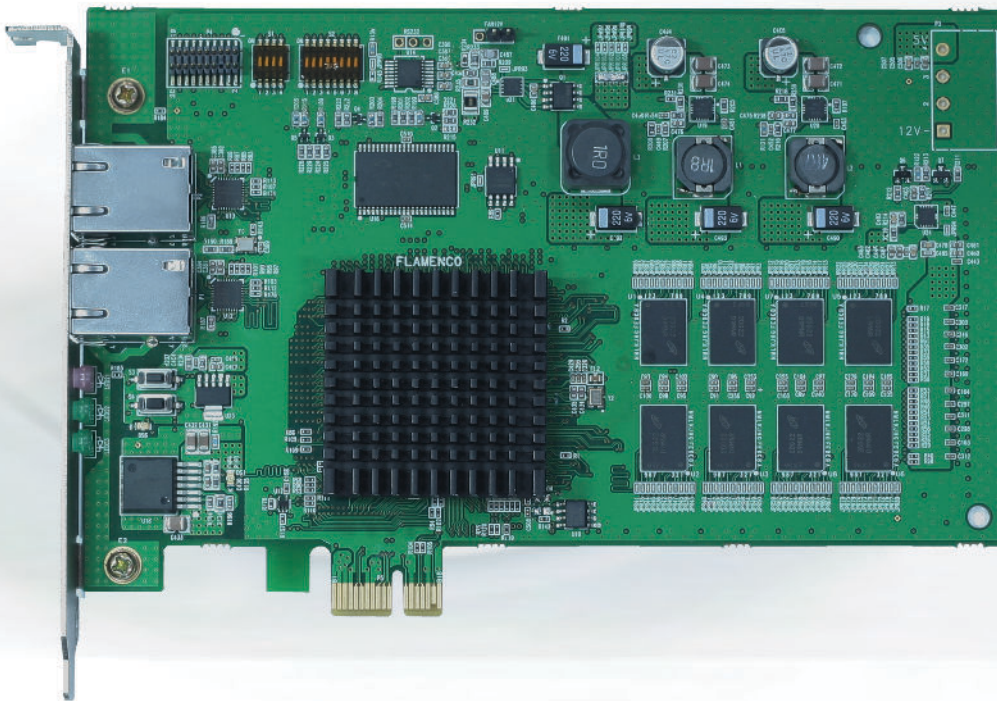

# NMC Series

NMC series is the best motion controller that has been developed based on 20 year's field experience.

## It is the best product to avoid complex equipment configuration

- A NMC can control up to 64 axes of Servo drives and 5,440 points of I/Os at every 1msec in position loop
- NMC can control Pulse/Analog Servo drive through function module.
- Max. four NMCs can be installed in a PC

**RS** Reliable & Smart  
**Automation**

## NMC lower the cost of a equipment

- Low-price PC can be used because of using PCIe slot
- Does not require Real Time OS  
(An advantage compared with software-motion-controller)
- Decreasing the number of wire can reduce wiring costs

**PCI**  
**EXPRESS™**

## Choose a EtherCAT master that you want

- The reasons are
- to support standard EtherCAT CoE
  - to support connection with all kinds of EtherCAT products
  - to support communication distance of 100m between nodes

**EtherCAT®**

## Apply our standardized and advanced Motion Controller to your equipment

- Perfectly realization of PLC Open Motion standard
- Overriding speed/position profile through various blending motion function
- API design that is familiar with PLC users

**PLCopen®**  
*for efficiency in automation*

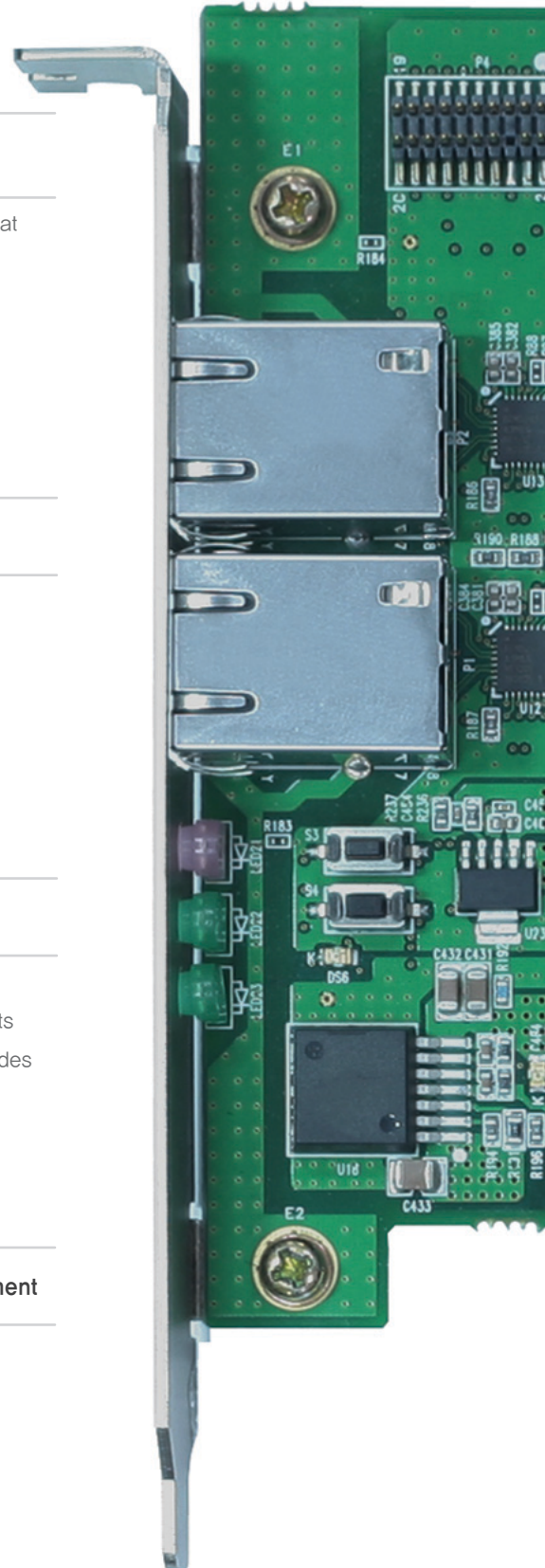

# EtherCAT System Configuration

Possible to build EtherCAT system you want as the lowest price.

## ■ Star wiring method

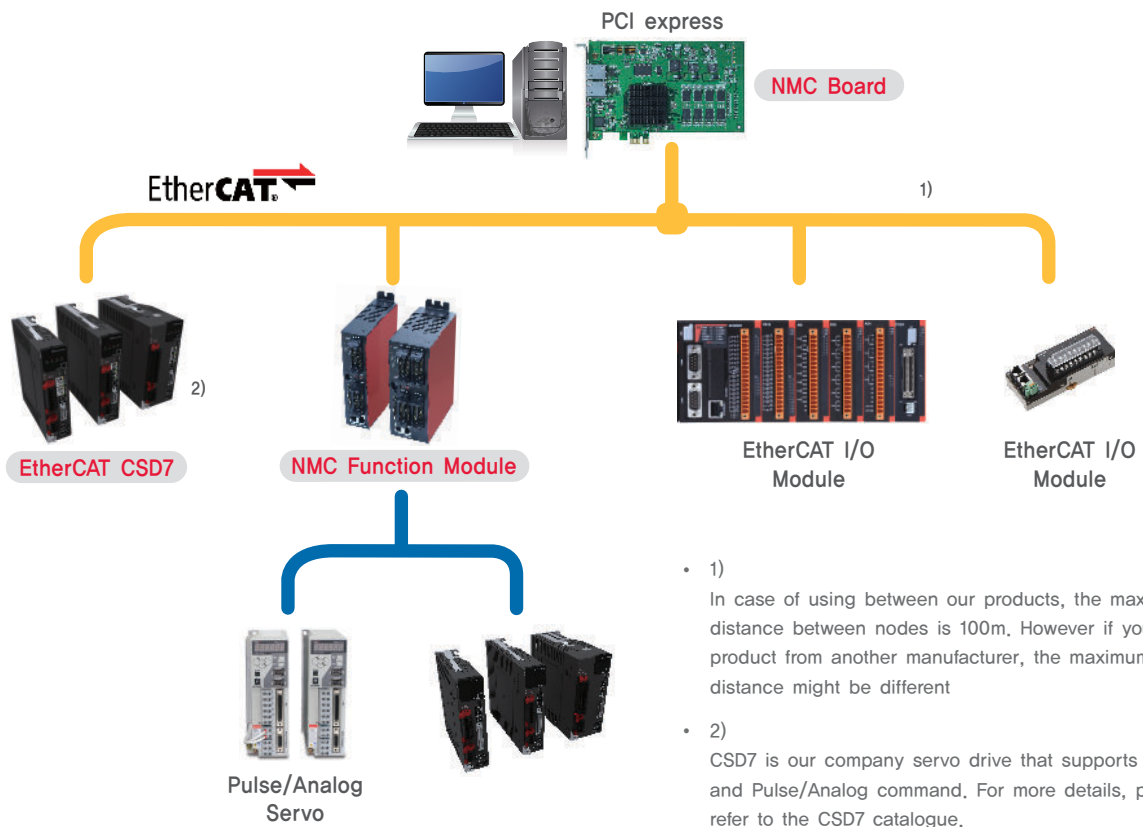

## ■ Line wiring method

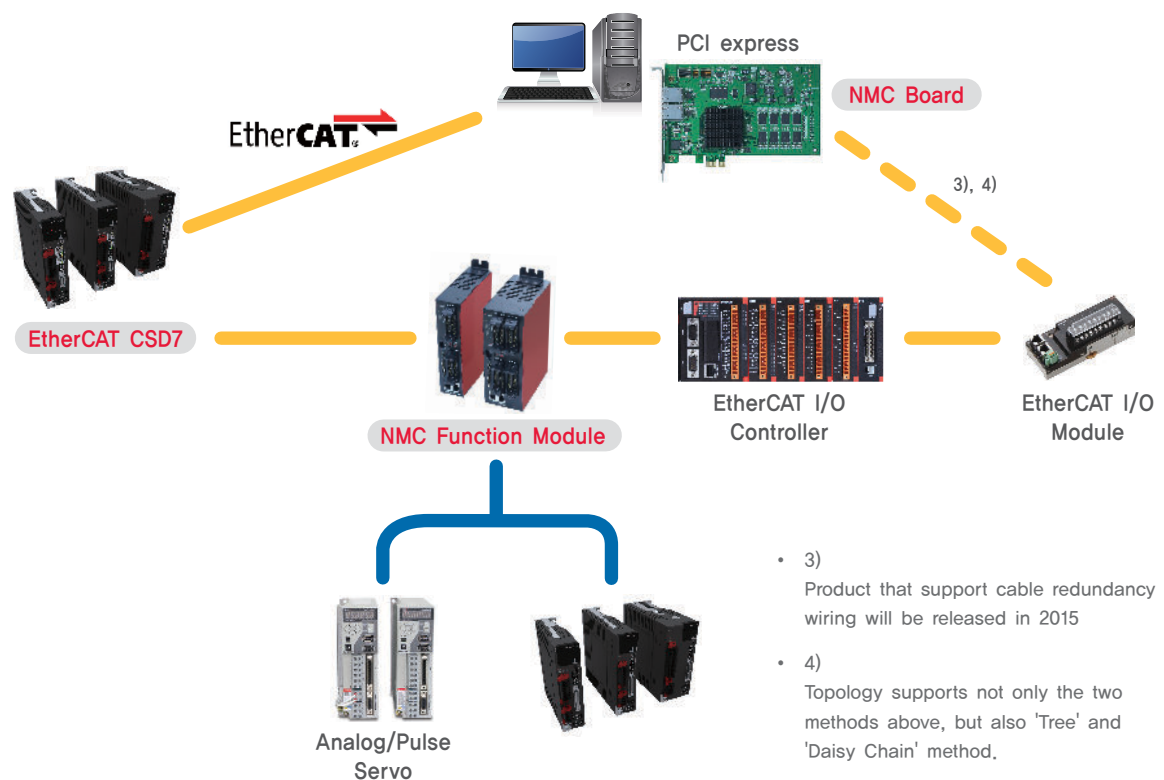

# Major functions of NMC (1)

Offers motion function suitable for gear controlling.

\* Planned

## Touch Probe

- A function that records actual position when specified input is triggered
- Processing time : 2ms

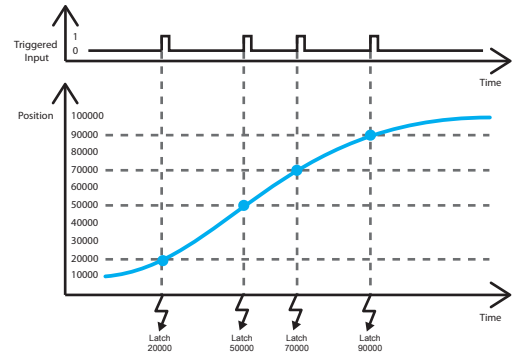

## Geared Motion

- A function that sets velocity ratio between Master axis and Slave axis
- No limitation about the number of Master axis and Slave axis
- A Master axis can have lots of Slaves, and one of these Slaves can be a Master of another axis

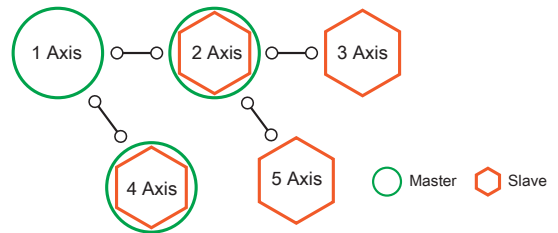

## Digital CAM Switch\*

- Function to output specified signal according to the condition of the certain switch set by selected axis
- Processing time : 2msec

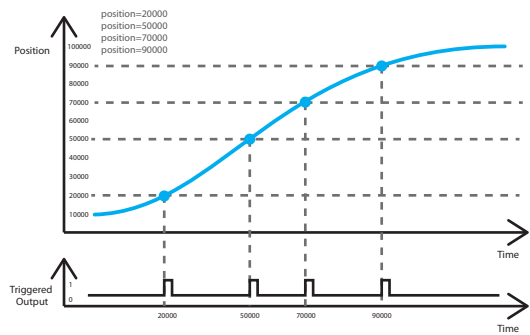

## Linear Absolute

- Function of rectilinear movement of the selected axes in a certain track
- Supports up to 3 axes
- Supports BLENDING \*

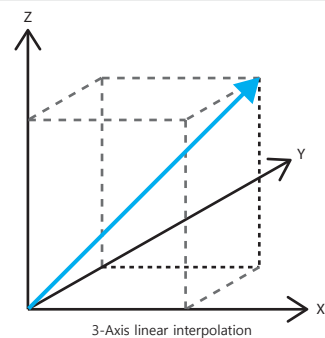

## Linear Circular

- This function enables the selected two axes to draw a circle arc to end position through auxiliary position.
- Supports up to 2 axes
- Supports two modes of 'Border' and 'Center'
- Supports BLENDING \*

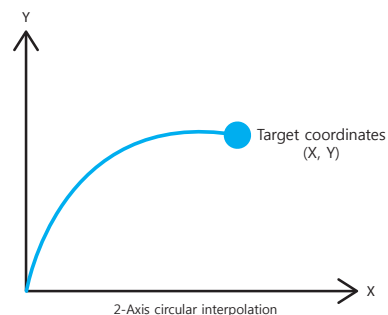

## Major functions of NMC (2)

NMC Series offers Position/Velocity Override function through six types of Blending as below. The function can be used on the Group Motion.

### Buffered

- Immediately starts a new movement after completion of the current movement
- Occurrence of a halt section as the speed zero between two movements
- There is no blending

### Aborting

- Default mode without buffering
- It makes an ongoing motion stop immediately

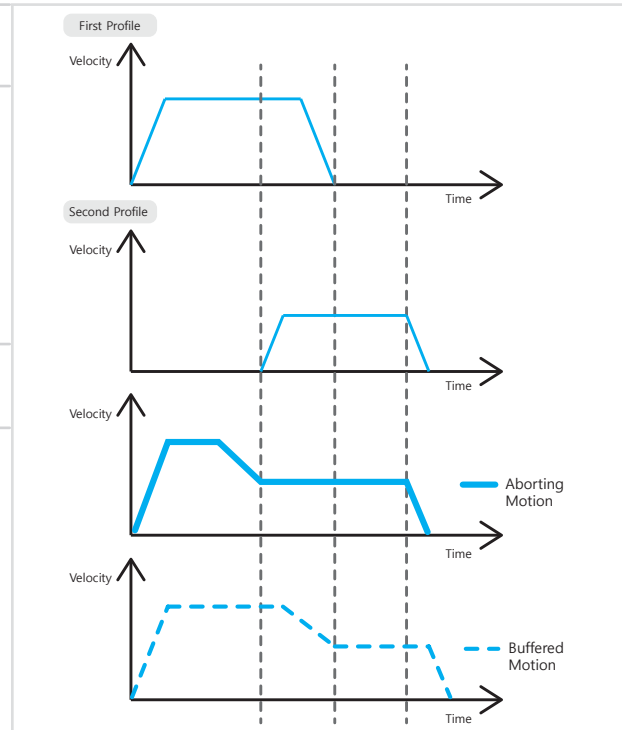

### BlendingLow

- The current movement is the same as buffered mode, but the axis will not stop between the movements.
- The velocity of the new movement is blended with the lowest velocity of the current and new movement at the end-position of the current movement

### BlendingHigh

- The current movement is the same as buffered mode, but the axis will not stop between the movements.
- The velocity of the new movement is blended with the highest velocity of the current and new movement at the end-position of the current movement

### BlendingPrevious

- The current movement is the same as buffered mode, but the axis will not stop between the movements.
- The velocity of the new movement is blended with the velocity of the current movement at the end-position of the current movement

### BlendingNext

- The current movement is the same as buffered mode, but the axis will not stop between the movements.
- The velocity of the new movement is blended with the velocity of the new movement at the end-position of the current movement

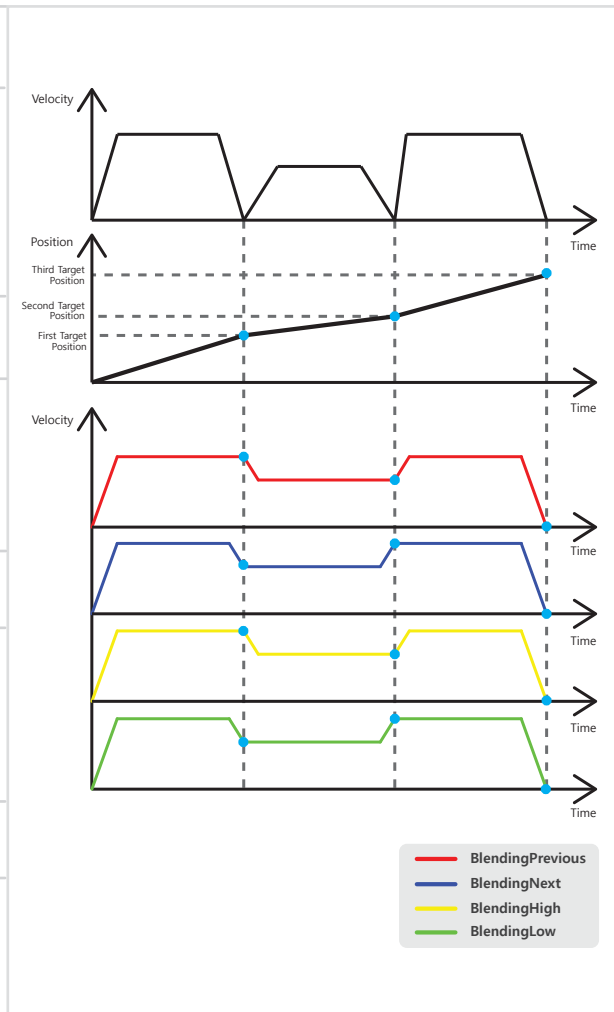

# NMC Manager

## ■ UI visible at a glance

NMC Manager is the tool developed by our company using the UI anyone can test our products without programming. Basically, it consists of the Motion Configuration that can test the axis operation directly, and the Device Configuration that can view the device information.

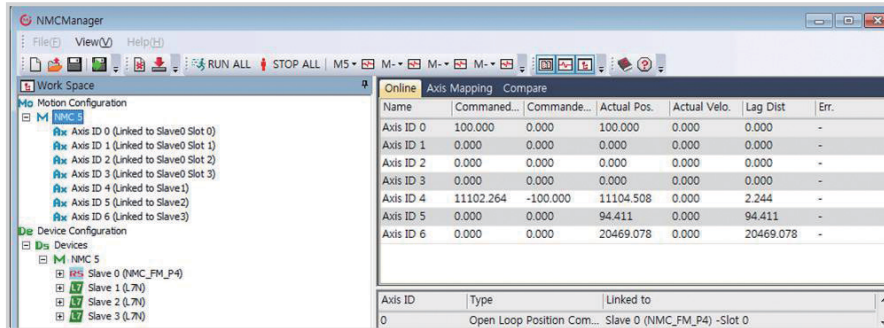

## ■ More comfortable composition of Axis Mapping

Any axis number and slave number can be changed as user desires using the Manager Software to avoid the axes configuration of the system.

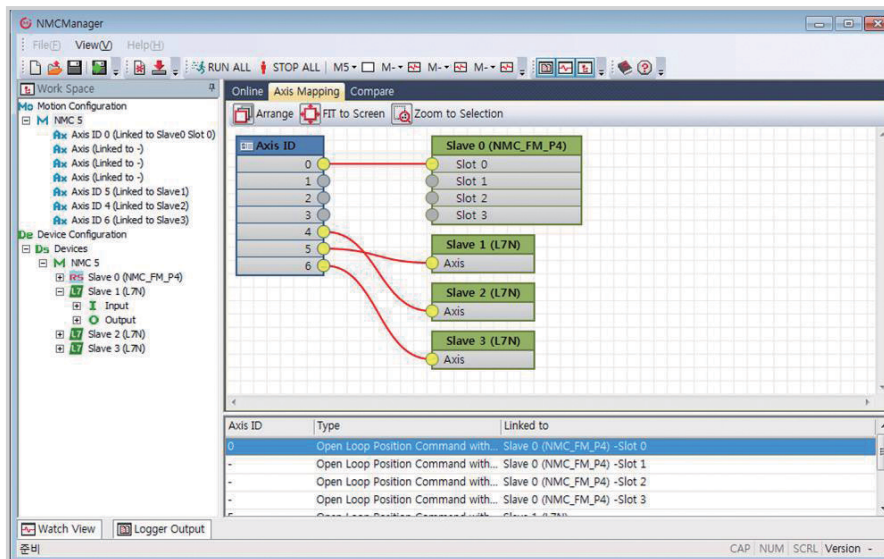

## ■ Convenient NMC Manager with automated SCAN SLAVE

It can be loaded the Project used before and the ENI file at the start of NMC Manager. It can operate up to the motor run easily without pressing any buttons using operation of automated SCAN SLAVE after a Master scan.

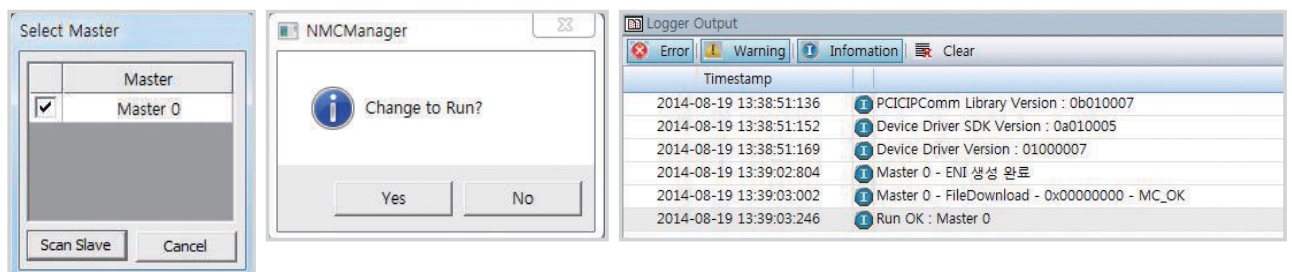

# NMC I/O Manager

## ■ Real time monitoring of EtherCAT Data being processed

It can read the communication status quickly and precisely because of sending and receiving real time processing data with NMC Manage connection.

It is a stand-alone and convenient software tool, because it is operated automatically after PC booting, without any actions, regardless of the NMC Manager.

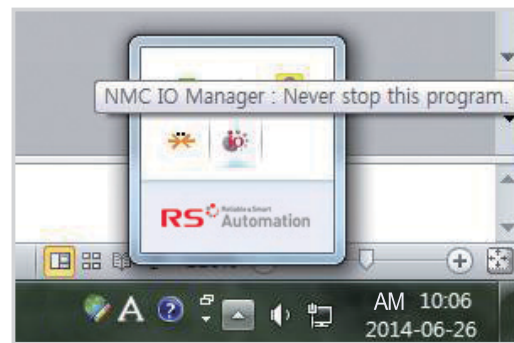
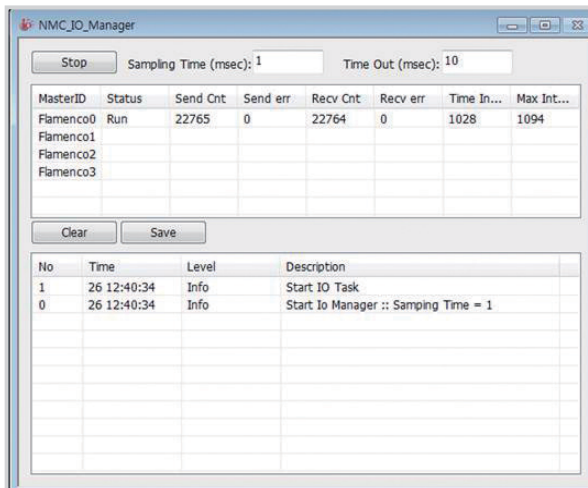

# NMC Scope

## ■ Individual NMC Scope Monitoring that is linked with NMC Manager

NMC Scope can check the data quickly and easily because it shows the position of the operating axes as the graph under the connection with NMC Manager. And multiful NMC Scope programs can be carried out for user convenience without mixing numbers of axes.

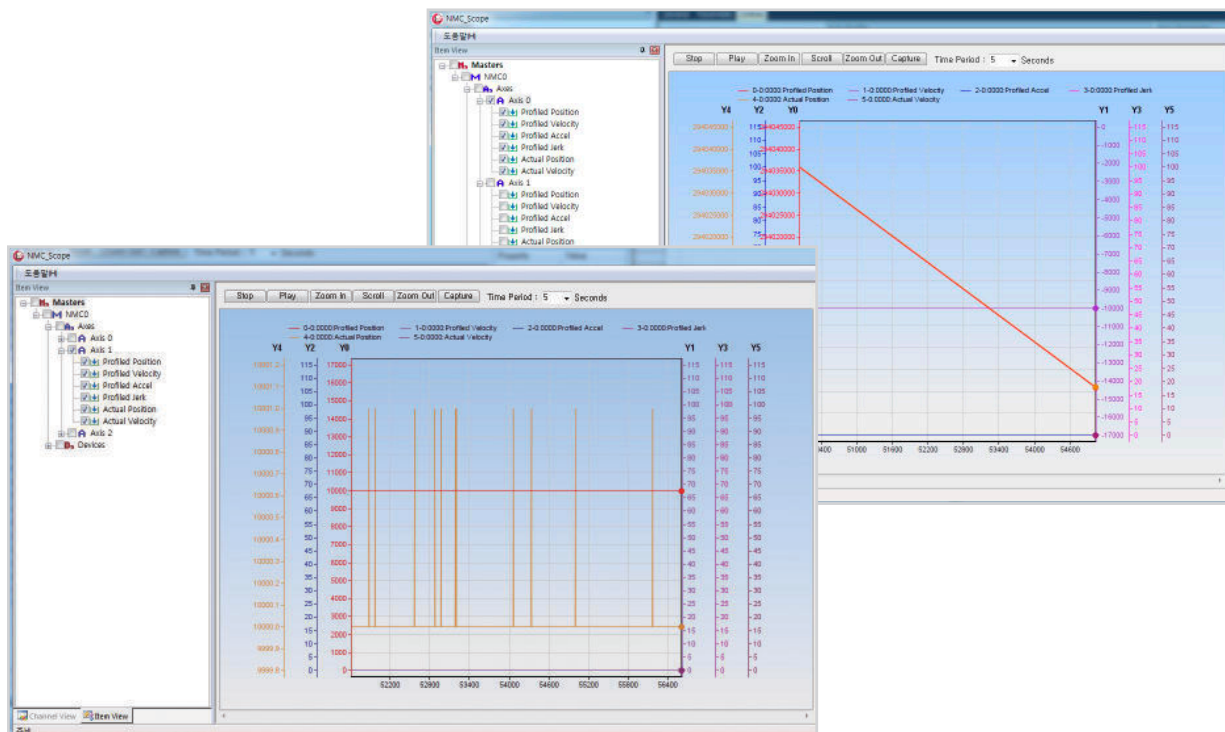

# NMC Master Board

The followings are the specification of the NMC series, NMC is the product that supports EtherCAT CoE and FoE. A NMC can control max, 64 axes and 5440 point I/Os.

## Types of Product

Catalog	Item	Control axes	Possible control mode	I/O support
MMC_BDPO08PCA		8	Position control	540 points
MMC_BDPO16PCA		16	Position control	1360 points
MMC_BDPO32PCA		32	Position control	2720 points
MMC_BDPO64PCA		64	Position control	5440 points

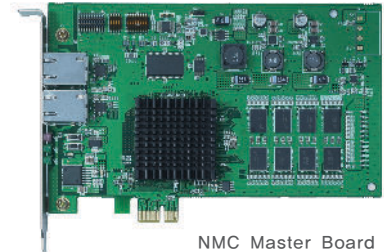

NMC Master Board

## Basic specifications

Item	specifications	Basic specifications
Communication method		EtherCAT 100Mbps Full Duplex
Control period		Position 1msec / 64 axes
Interface		PCI-Express 1x to PC EtherCAT to Slave
Controllable axes		Max, 64Axis / Board
Usable I/O		Max, 5,440Points / Board
Installable NMC quantities per a PC		4EA (256 Axis, 21,760 Points IO)
Speed profile		Symmetry/Asymmetry trapezoid, Symmetry/Asymmetry acceleration or deceleration.
Operating method		Linear interpolation, Circular interpolation, Spline interpolation, Override, Touch probe
Input power		PC Power 3.3V, 12V Main Power source
Using environment		0°C ~ 50°C (5~85%, Non-condensing)
OS		32/64 bit, Windows 7, Windows 8
Software		Visual C++, Visual Basic

## Dimensions

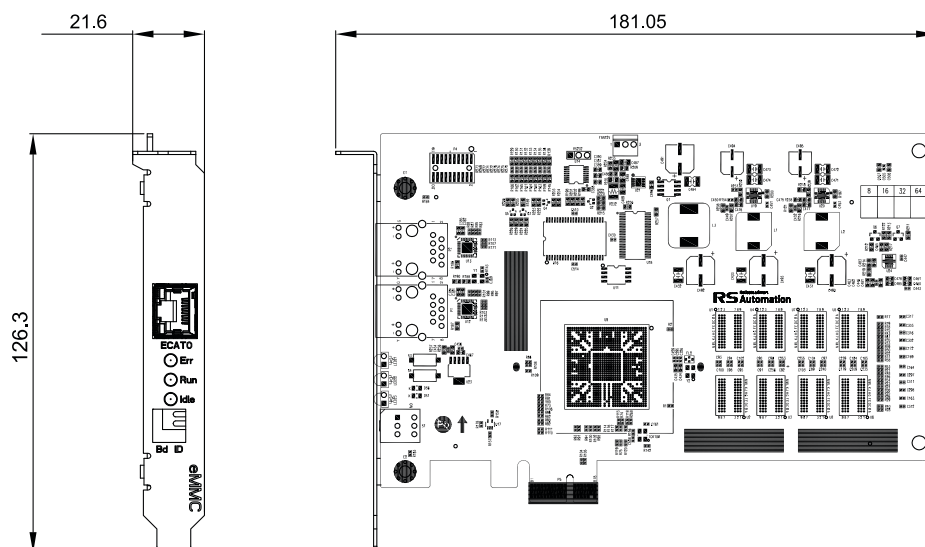

# NMC Function Module

The followings are the specification of the Function Module that is option product to connect Pulse/ Analog Servo drive or step motor drive that don't have EtherCAT function.

## Types of product

Catalog	Item	Control axes	Controllable Servo drive	Built-in I/O
MMC_CS04A		4	Position control type	10/10 points
MMC_CS08A		8	Position control type	20/20 points



NMC Function Module

## Basic specifications

Item	specifications	Basic specifications
Communication method		EtherCAT 100Mbps Full Duplex
Pulse command		Max 16MHz
Encoder counter input		Max 32MHz (x4 Based)
System I/O		Axis Enable, Axis Fault Reset
		Axis Alarm In, In Position
User I/O		Max. 20/20 point (8 axes module)
Limit sensor		3 Limit sensors (Home, Positive, Negative)
Input Power		DC 24±10%, Max 2.7A
Using environment		0°C ~ 50°C (5~85%, Non-condensing)
Mounting method		Wall Mount, Rack Mount support
Size		4 axes : 41mm(W) x 160mm(H) x 120mm(D)
		8 axes : 64mm(W) x 160mm(H) x 120mm(D)

## Dimensions (Unit of measure : mm)

NMC Function Module (4-axes)

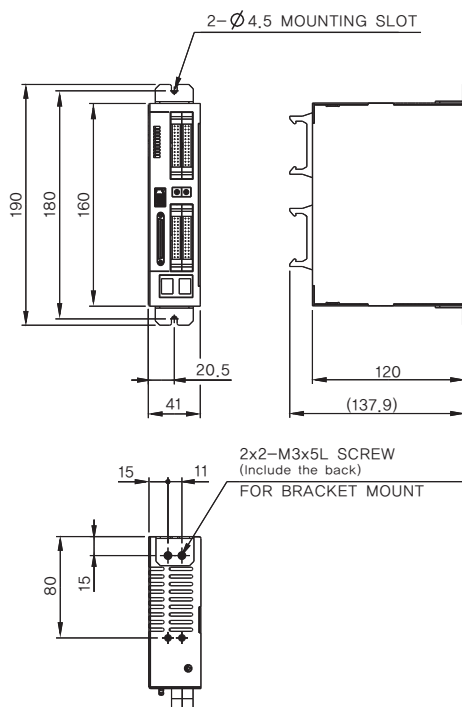

NMC Function Module (8-axes)

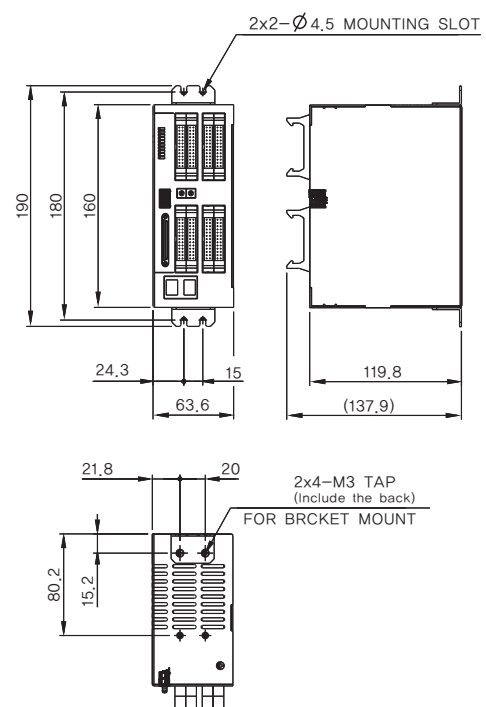

# NMC wiring

The following specification of the cable is the recommendation from our company.

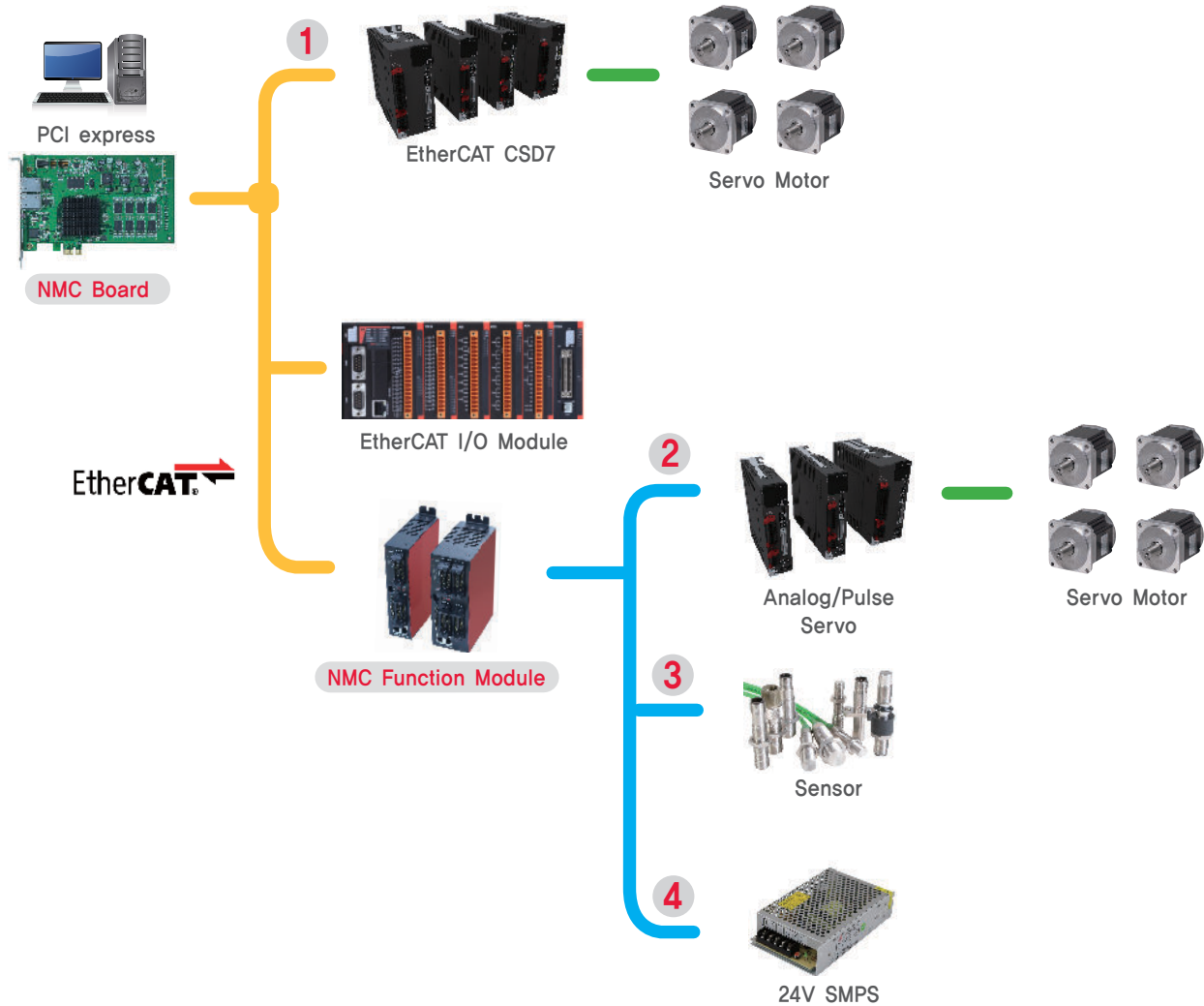

## Basic specifications

No.	Use	Shape of Cable harness	Connector spec.	Max. length	Remark
1	EtherCAT Cable		3R108-0000-000 CE [3M]	100M	Please use the recommended cable, cable length and connector.
2	AX 0~7 (Axis Cable)		HIF3BA-26DA [HIROSE]	5M	Servo drive connectors are in conformity with its manufacturer
3	I/O Cable		HDRA-E68MA1 HDRA-E68GKPE [HONDA]	-	The length is in conformity with sensor
4	DC(Power) Cable		372 Series [3M]	-	The Connector is provided by our company

[Notice] 1. Please refer to the page on the right to search a detailed pin map of wiring.  
2. We don't sell any wiring cables for NMC Series.

# NMC Function Module

## ■ DC IN

Pin	Signal	Description	Pin	Signal	Description	Pin	Signal	Description
1	+	24V Power	2	FG	Frame Ground	3	-	24V Ground

## ■ AX0 – AX7

Pin	Signal	Description	Pin	Signal	Description
A1	ANALOGx	Analog output	A14	CCW-	Step Sign(CCW)-
A2	DGND	Digital Ground	A15	CW+	Step Sign(CW)+
A3	Z+	Z pulse(or index)+	A16	CW-	Step Sign(CW)-
A4	Z-	Z pulse(or index)-	A17	N/C	N/C
A5	B+	Encoder B+	A18	N/C	N/C
A6	B-	Encoder B-	A19	AMP_On	Servo ON Output
A7	A+	Encoder A+	A20	ALARM	Servo Alarm Input
A8	A-	Encoder A-	A21	ALM_RSTx	Servo Alarm Reset
A9	ABS+	Encoder ABS+	A22	INPOS	In Position Input
A10	ABS-	Encoder ABS-	A23	N/C	N/C
A11	PCLR+	Pulse Clear+	A24	N/C	N/C
A12	PCLR-	Pulse Clear-	A25	IO_G24V	IO 24V Ground
A13	CCW+	Step Sign(CCW)+	A26	IO_P24V	IO 24V Power

## ■ I/O

Pin	Signal	Description	Pin	Signal	Description
1	OUTPUT 0	Digital Output 0	35	INPUT 7	Digital Input 7
2	OUTPUT 10	Digital Output 10	36	INPUT 17	Digital Input 17
3	OUTPUT 1	Digital Output 1	37	INPUT 8	Digital Input 8
4	OUTPUT 11	Digital Output 11	38	INPUT 18	Digital Input 18
5	OUTPUT 2	Digital Output 2	39	INPUT 9	Digital Input 9
6	OUTPUT 12	Digital Output 12	40	INPUT 19	Digital Input 19
7	OUTPUT 3	Digital Output 3	41	POS_LIMIT 0	Positive Limit 0
8	OUTPUT 13	Digital Output 13	42	POS_LIMIT 4	Positive Limit 4
9	OUTPUT 4	Digital Output 4	43	POS_LIMIT 1	Positive Limit 1
10	OUTPUT 14	Digital Output 14	44	POS_LIMIT 5	Positive Limit 5
11	OUTPUT 5	Digital Output 5	45	POS_LIMIT 2	Positive Limit 2
12	OUTPUT 15	Digital Output 15	46	POS_LIMIT 6	Positive Limit 6
13	OUTPUT 6	Digital Output 6	47	POS_LIMIT 3	Positive Limit 3
14	OUTPUT 16	Digital Output 16	48	POS_LIMIT 7	Positive Limit 7
15	OUTPUT 7	Digital Output 7	49	HOME 0	Home input 0
16	OUTPUT 17	Digital Output 17	50	HOME 4	Home input 4
17	OUTPUT 8	Digital Output 8	51	HOME 1	Home input 1
18	OUTPUT 18	Digital Output 18	52	HOME 5	Home input 5
19	OUTPUT 9	Digital Output 9	53	HOME 2	Home input 2
20	OUTPUT 19	Digital Output 19	54	HOME 6	Home input 6
21	INPUT 0	Digital Input 0	55	HOME 3	Home input 3
22	INPUT 10	Digital Input 10	56	HOME 7	Home input 7
23	INPUT 1	Digital Input 1	57	NEG_LIMIT 0	Negative Limit 0
24	INPUT 11	Digital Input 11	58	NEG_LIMIT 4	Negative Limit 4
25	INPUT 2	Digital Input 2	59	NEG_LIMIT 1	Negative Limit 1
26	INPUT 12	Digital Input 12	60	NEG_LIMIT 5	Negative Limit 5
27	INPUT 3	Digital Input 3	61	NEG_LIMIT 2	Negative Limit 2
28	INPUT 13	Digital Input 13	62	NEG_LIMIT 6	Negative Limit 6
29	INPUT 4	Digital Input 4	63	NEG_LIMIT 3	Negative Limit 3
30	INPUT 14	Digital Input 14	64	NEG_LIMIT 7	Negative Limit 7
31	INPUT 5	Digital Input 5	65	IO_P24V	24V Power
32	INPUT 15	Digital Input 15	66	IO_P24V	24V Power
33	INPUT 6	Digital Input 6	67	IO_G24V	24V Ground
34	INPUT 16	Digital Input 16	68	IO_G24V	24V Ground

**RS Automation Co., Ltd.**  
**www.rsautomation.biz**

38, Jinwisandan-ro, Jinwi-myeon, Pyeongtaek-si, Gyeonggi-do, Korea,  
Zip code : 451-862

T 82-31-685-9300, F 82-31-685-9500

RS Automation Global Business Support  
rsagbs@rsautomation.biz

**京畿道平泽市振威面振威产团路38 #451-862**

T 82-31-685-9300, F 82-31-685-9500

RS自动化全球商户支持  
rsagbs@rsautomation.biz