

Bulletin 1692 Electronic Circuit Protection Module 1692-ZRCLSS Series



Protection Module

- One Input and Four Current Controlled Outputs
- NEC Class 2 Compliant Outputs
- Monitors input voltage supply and limits current to the loads
- Protects Small Cable Sizes against Overload
- Hassle-free Turn-on of Loads with Large Input Capacitors
- Wide Temperature Range between -25 °C ...+70 °C
- On/Off Function of Outputs
- Compact Design— Width only 45 mm
- Remote Monitoring and Control Functions



General Specifications	
Input voltage	24V DC
Input voltage range	18 - 30V
Input current (at no load)	typ. 43 mA
Number of outputs	4
Output currents	4x3.7 A at 24V 4 x 3.2 A at 28V
Input voltage protection levels	typ. 21.4V
Operating Temperature	-25°C ...+70°C
Storage Temperature	-40°C ... +85°C
Type of current limitation	Active current limitation followed by a shutdown
Dimensions (w x h x d)	45 x 75 x 91mm ②

② Add 13mm in depth for signal connector.





Catalog Number	Output Ratings
1692-ZRCLSS	(4) NEC Class 2 circuits (100 VA /circuit max)

Contents

Product Description	2
Installation Requirements	3
Input	4
Outputs	4
Current Limitation and Shutdown Behavior	5
Connecting Capacitive Loads to the Outputs	6
Output-OK Relay Contact	7
ON/OFF and Reset Signal Input	8
Synchronization of Multiple 1692 Modules	8
Functional Diagram	9
Back-feeding Loads	9
Power Losses	9
Reliability	10
Front Side and User Elements	11
Terminals and Wiring	12

EMC	13
Environment	14
Protection Features	15
Dielectric Strength	15
Approvals	16
Fulfilled Standards	16
Used Substances	16
Physical Dimensions and Weight	17

Standards and Certifications

UL 508 	UL 60950-1 	UL 2367 
IEC 60950-1 		EMC, LVD 

Terminology and Abbreviations

DC 24V— A figure displayed with the AC or DC before the value represents a nominal voltage with standard tolerances (usually $\pm 15\%$) included. E.g.: DC 12V describes a 12V battery disregarding whether it is full (13.7V) or flat (10V)

24Vdc— A figure with the unit (Vdc) at the end is a momentary figure without any additional tolerances included.

Intended Use

This device is designed for installation in an enclosure and is intended for the general use such as in industrial control, office, communication, and instrumentation equipment.

Do not use this power supply in aircraft, trains, nuclear equipment or similar systems where malfunction may cause severe personal injury or threaten human life.

This device is designed for use in non-hazardous, ordinary or unclassified locations.

Product Description

This protection module fulfills two basic functions. First it distributes the current of a large power source to four lower current output channels and therefore allows for smaller wires to be used. The second function is to permit only so much current on the outputs that the input voltage of this unit (which corresponds to the output voltage of the power supply) does not fall below 21V. This ensures a reliable supply voltage for sensitive equipment, such as PLCs, controls or sensors, when they are connected directly to the same power supply as the Bulletin 1692 protection module.

The protection module has one 24V input and four output channels to which the current is distributed. Each output channel is equipped with a redundant over-current protection, which avoids that wires will be overloaded. All four output channels will shutdown simultaneously, if the current of one individual channel or the maximum allowed current for the protection module is exceeded.

A voltage monitor in the input stage of the Bulletin 1692 module works like a valve. It permits only so much current that the input voltage does not drop below 21V. In case the input voltage would fall below this value (e.g. due to overloads, too small of a power supply or high inrush currents such as from starting a motor), all four output channels will be actively current limited and will shutdown after a certain period of time.

Figure 2

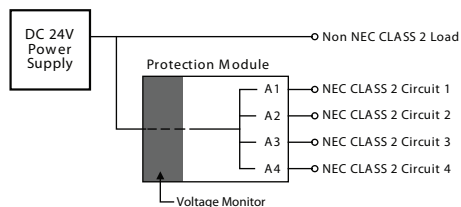

A typical wiring configuration is shown in Figure 2. All sensitive loads are connected directly to the power supply. If needed, these load circuits can be protected with standard circuit breakers or fuses. Loads which are less sensitive to voltage dips or interruptions or which are the source of the voltage drop themselves are connected to the output of the Bulletin 1692 protection module.

Installation Requirements

This protection module is suitable for DIN-rail mounting. Use DIN-Rails according to EN 60715 or EN 50022 with a height of 7.5 or 15mm.

The protection module can be used with any regulated 24Vdc power supply. If the power source can deliver more than 40A continuous, the Bulletin 1692 module shall be equipped with an external input circuit protection (fuse/circuit breaker) (e.g. 30/32A). The power capability and performance of the power supply can limit the output characteristics of the Bulletin 1692 module.

- Make sure that the input voltage polarity is correct before applying the input voltage.
- Do not connect batteries to the outputs of the Bulletin 1692 module.
- This device may only be installed and put into operation by qualified personnel.
- The unit does not contain serviceable parts.
- If damage or malfunction should occur during operation, immediately turn power off and send unit to the factory for inspection.
- This device is designed for convection cooling and does not require an external fan. Do not obstruct airflow and do not cover ventilation grid.
- The standard mounting orientation is input terminals on the bottom and output terminals on the top. Do not use the unit in other mounting orientations.
- Keep the following installation clearances:
 - 40mm on top, 20mm on the bottom
 - Left / right: 0mm (or 15mm in case the adjacent device is a heat source; in example another power supply).

A high voltage drop between the power supply and the protection module might cause a malfunction. It is not recommended to use wires longer than 2x2 m (for 2.5 mm² or AWG 14 wires) or 2x4 m (for 4 mm² or AWG 12 wires) to avoid undesired undervoltage conditions on the input of the protection module.

At ambient temperatures above 50°C and output currents higher than 15A (sum of all four channels), do not use a wire size smaller than 2.5mm² (or AWG14) and use wiring scheme 5-13-2.

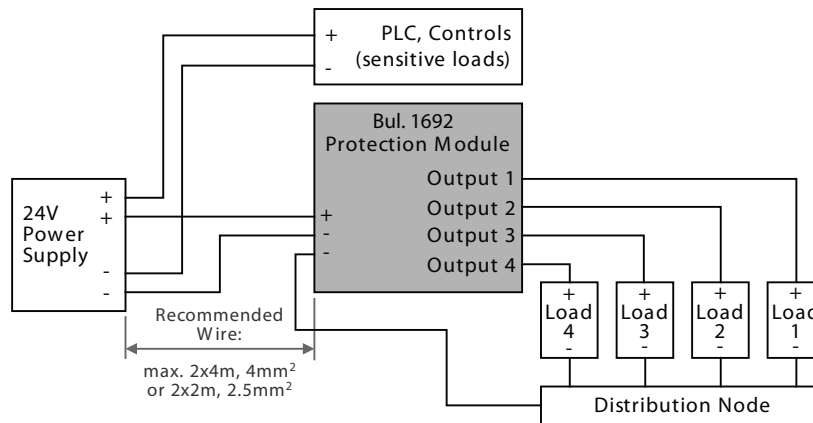

WARNING: Risk of electrical shock, fire, personal injury or death.

1. -Turn power off before working on the device. Protect against inadvertent re-powering.
2. -Make sure that the wiring is correct by following all local and national codes.
3. -Do not modify or repair the unit.
4. -Do not open the unit.
5. -Use caution to prevent any foreign objects from entering the housing.
6. -Do not use in wet locations or in areas where moisture or condensation can be expected.

Input

Input voltage	nom.	DC 24V	±25%
Input voltage range	-	18V DC...30V DC	
	max.	30V DC	Absolute maximum continuous input voltage with no damage to the Bulletin 1692 module
Turn-on voltage	typ.	21.4V DC	Required input voltage for turning-on the outputs
Turn-on delay of outputs	typ.	270ms	Period between applying the input voltage and turning on the outputs. All outputs will be turned-on at the same time.
Input voltage protection level ❶	min. max.	21.0V DC 21.8V DC	Below this voltage level, outputs will shutdown.
Stand-by input current	typ.	43 mA	Stand-by current with no load current on the outputs

❶ Voltage dips below this value can occur for maximal 200µs.

Outputs

		24V Output	28V Output
Output Current	output 1	3.7 A	3.2 A
	output 2	3.7 A	3.2 A
	output 3	3.7 A	3.2 A
	output 4	3.7 A	3.2 A
	All 4 outputs together	14.8 A	12.8 A
Output current limitation ❷	min.	16.6	16.6
	typ.	19.9	19.9
	max.	23.6	23.6
Voltage Drop ❸	typ.	92 mV	92 mV

❷ The current limitation value for the sum of all four output currents. This current can be drawn from each individual output regardless whether it is a 1A, 2A, 3A, 4A, 6A, 10A or 12A output. According to the specified ampacity of the outputs, the current can flow for a shorter or longer period before the protection module shutdown all four outputs at the same time.

❸ Voltage loss between input and output, when all output channels are loaded with 50% of its nominal current

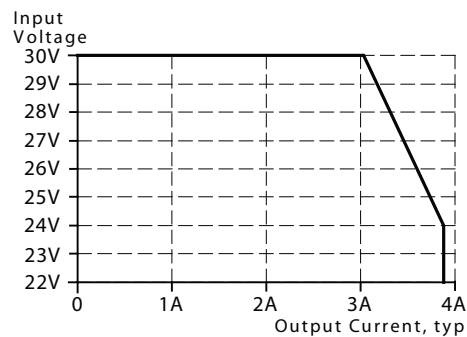

Current Limitation and Shutdown Behavior

The Bulletin 1692 protection module comprises one common limitation and switching element for all four outputs. In a protection event, all four outputs limit the current or shutdown at the same time.

The following reasons can cause a limitation of the output currents or a shutdown of the output channels:

1. The output current of one or more output channels was too high.
2. The sum of the output current of all four output channels was exceeded.
3. The outputs needed to be shutdown in order to maintain sufficient input voltage.

Shutdown times when exceeding the rated output current:

Shutdown Times		
At 2x the rated current	typ.	1 s at 7.4A
At short circuit	typ.	5 ms at 23.6A

-  The timer for shutdown starts immediately once the rated current levels are exceeded. All output channels will shutdown, if one channel is overloaded. A shutdown of the outputs can also happen earlier, e.g. when the Bulletin 1692 module has to protect the supply voltage in case the power supply can not deliver enough current to support all loads without going into overload.

Figure 5: Shutdown characteristics



Shutdown behavior to avoid under-voltage situations on the supply voltage

A further limitation of the output current activates when the supplying power source can not deliver enough current to support all loads without bringing the power source into overload followed by a voltage drop. In such an event, the voltage dependent current limitation of the input stage of the protection module is activated (voltage monitoring). The voltage monitor acts like a valve only permitting so much current so that the supply voltage does not fall below 21V. The period of time for how long the protection circuit is able to actively limit the current depends on the difference between input and output voltage and the current which flows through the Bulletin 1692 protection module and is limited to a maximum of 5s. All four outputs will shutdown simultaneously.

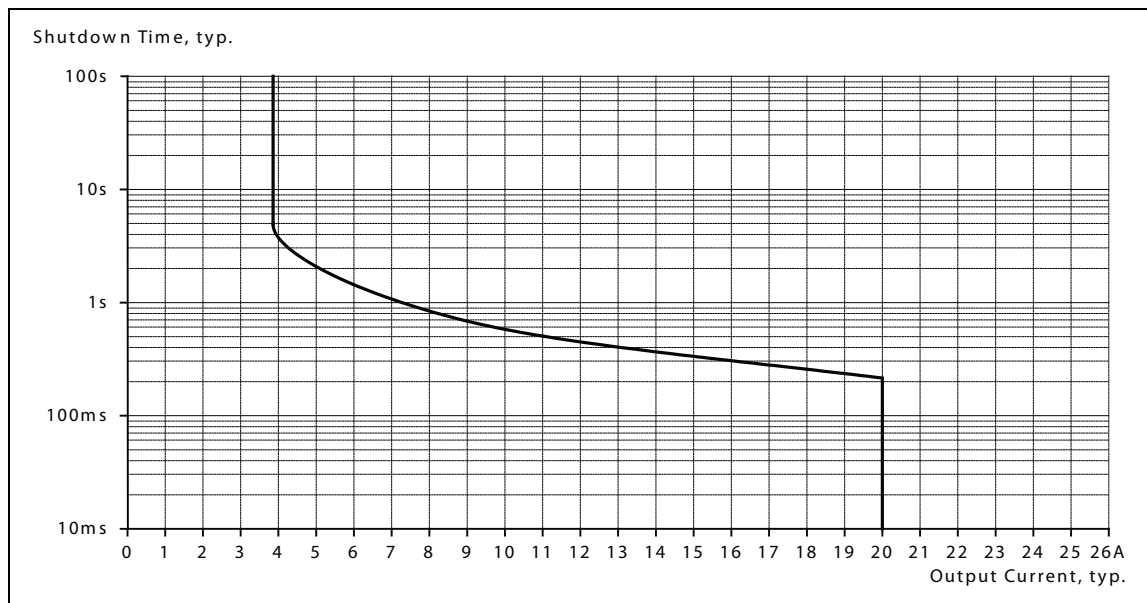
Figure 6: **Active current limitation – Period of time in current limiting mode until the outputs will shutdown**

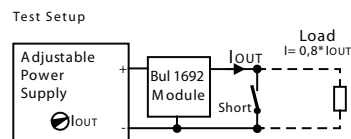
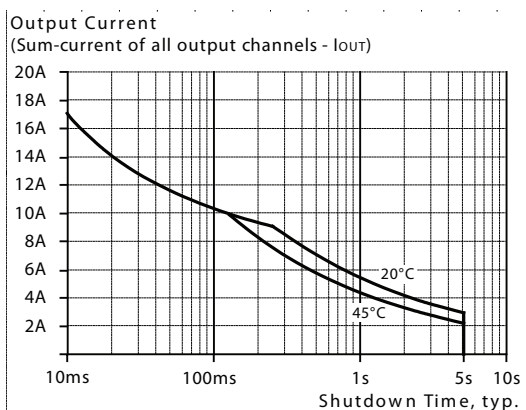

Test Procedure:

1. Set the output current of the adjustable power supply to the test current value.
2. Set load current to 80% of the test current and wait for a thermally stable condition.
3. Short circuit the output of the Bulletin 1692 module and measure the time until the outputs shutdown.

No single output channel is allowed to be overloaded
 The output current is the sum of all outputs.

Connecting Capacitive Loads to the Outputs

Large input capacitors of drives, monitors or other similar loads can result in an unintended shutdown of the module when trying to turn-on such loads. This especially can occur after a reset or by turning on a load via the push button or the external signal input. The Bulletin 1692 protection module is designed to be exceptionally compatible with such types of loads. The module can turn-on as much capacitance as possible and comprises several different protection mechanisms to protect against an unintended shutdown or damage of the unit.

The permissible capacitor sizes which can be connected to the output of the Bulletin 1692 module depends on the load current itself as well as on the characteristic of the load.

The following tables show two typical cases (case A and case B) for the permissible capacitors, which can be connected on the outputs without shutdown of the protection module. The listed values are valid for the entire temperature range.

Case A: All outputs are loaded.

The minimum values are worst-case figures for the permissible capacitors which are defined with an additional constant current load and with the maximum permissible total current of the Bulletin 1692 protection module.

The typical values are defined with an additional resistive load. See also the parameter list below the table.

Per channel	typ.	50 mF
	min.	15 mF
All four outputs together	typ.	50 mF
	min.	15 mF

Typical values are with an additional 1.9A resistive load per output
Minimum values are with an additional 3.7A constant current load per output

Case B: Only one output is loaded

The minimum values for the permissible capacitors are defined with an additional constant current load according to the parameter list below. During the tests, only one output is loaded and all others are not.

The typical values for the permissible capacitors are defined with an additional resistive load according to the parameter list below. During the tests, only one output is loaded and all others are not.

Per channel	typ.	50 mF
	min.	15 mF
All four outputs together	typ.	50 mF
	min.	15 mF

Typical values are with an additional 1.9A resistive load per output
Minimum values are with an additional 3.7A constant current load per output

Output-OK Relay Contact

This relay contact is close when the input voltage is sufficient and the outputs are not shutdown.

Threshold voltage (Required voltage to power the relay and to close the relay contact. The outputs must also not be shutdown.)	typ.	21.4Vdc
Contact ratings —Resistive load	max.	30Vdc, 1.0A
	max.	30Vac, 0.5A
	min.	1mA at 5Vdc
Galvanic isolation —Test voltage: Signal path to power path	nom.	500Vac

ON/OFF and Reset Signal Input

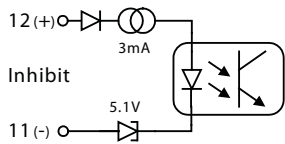

Figure 7

This signal input is galvanically isolated with an integrated optocoupler and works in the same manner as the reset and ON/OFF button. The ON/OFF function has no safety feature included.

Signal Voltage	max.	21.4Vdc
Signal Current	typ.	30Vdc, 1.0A
	max.	30Vac, 0.5A
Threshold Voltage Levels	min.	6V DC
	max.	10V DC
Galvanic isolation —Test voltage: Signal path to power path	nom.	500V AC

In a failure mode (outputs have shutdown), the outputs can be turned on again by applying a voltage for more than 1 second. In normal mode (outputs have not shutdown), a short (> 50ms) voltage—all outputs ON or OFF. The unit will be shipped (factory setting) with the outputs turned-on.

ON/OFF	>50ms signal
Reset	1 second signal

Synchronization of Multiple Bulletin 1692 Modules

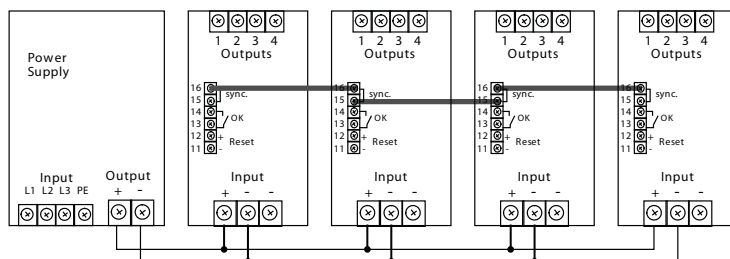

Figure 8

If multiple Bulletin 1692 modules are used on the same power supply, it is recommended to connect the sync. bus of all modules together.

If one unit shuts down due to the protection function of the input voltage protection circuit (voltage monitor), all other modules will shutdown too.

This avoids a false interpretation of which output channel caused the problem. If the sync. terminals are not linked, the module with the highest voltage monitor protection voltage level (caused by tolerances) would shutdown first regardless whether the failure was caused by this module or not.

Please note:

If the cause for the shutdown was an over-current of one individual channel only this module will shutdown and the other modules will stay on. In this case the sync. line has no impact on the other modules.

If the application requirement is to shutdown all outputs then use your control logic system to control each module with dedicated reset signal.

Functional Diagram

Figure 9: **Functional Diagram**

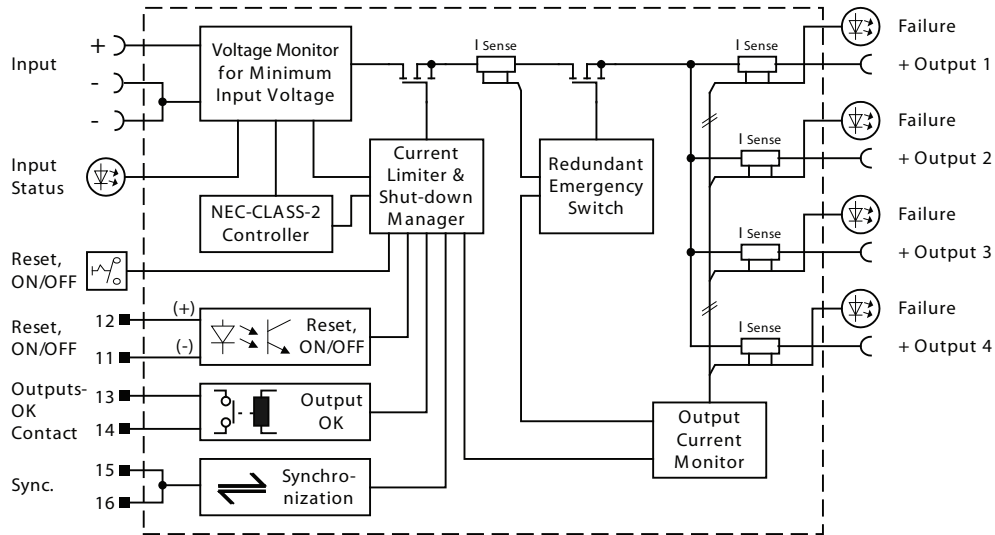

Back-feeding Loads

Loads such as decelerating motors and inductors can feed voltage back to the Bulletin 1692 protection module. This feature is also called return voltage immunity or resistance against Back- E.M.F. (Electro Magnetic Force).

The protection module is resistant and does not show malfunctioning when a load feeds back voltage up to 30Vdc to the protection module. It does not matter whether the protection module is on or off.

The protection module has no capability to absorb energy. Internal diodes (integrated body diodes of the Mosfets) direct the voltage and energy to the power supply, which is connected on the input side of the protection module. The power supply defines the amount of energy which can be absorbed.

Power Losses

No-load losses	typ.	1.0 W
Losses at typical output loads ^{*)}	typ.	1.6 W

*) Typical value when all output channels are loaded with 50% of its nominal current.

Reliability

The Allen-Bradley Bulletin 1692 protection modules are extremely reliable and use only the highest quality materials. The number of critical components such as electrolytic capacitors have been reduced.

Applied load	
Lifetime expectancy ❶	
40°C	220 000 h
25°C	622 000 h
MTBF ❷ SN 29500, IEC 61709	
40°C	2 198000 h
25°C	3 784000 h
MTBF ❷ MIL HDBK 217F, GB	
40°C	734 000 h
25°C	1 009 000 h

- ❶ The Lifetime expectancy shown in the table indicates the minimum operating hours (service life) and is determined by the lifetime expectancy of the built-in electrolytic capacitors. Lifetime expectancy is specified in operational hours and is calculated according to the capacitor's manufacturer specification. The manufacturer of the electrolytic capacitors only guarantees a maximum life of up to 15 years (131 400h). Any number exceeding this value is a calculated theoretical lifetime which can be used to compare devices.
- ❷ **MTBF** stands for **Mean Time Between Failure**, which is calculated according to statistical device failures, and indicates reliability of a device. It is the statistical representation of the likelihood of a unit to fail and does not necessarily represent the life of a product.

The MTBF figure is a statistical representation of the likelihood of a device to fail. A MTBF figure of e.g. 1 000 000h means that statistically one unit will fail every 100 hours if 10 000 units are installed in the field. However, it can not be determined if the failed unit has been running for 50 000h or only for 100h.

Front Side and User Elements

Figure 10

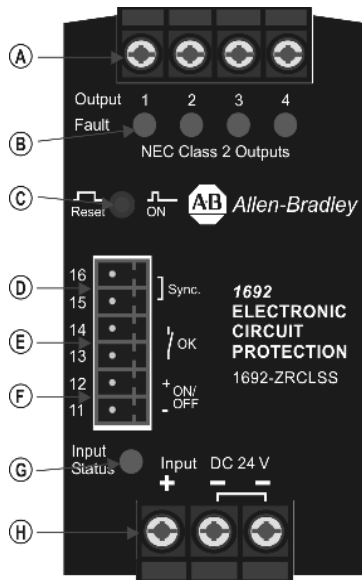

A—Output Terminals (plus (+) pole connection points)

B—Red Failure LEDs The red LEDs are failure indicators. Any time a red LED is on or blinking, the outputs have been shutdown. Three reasons why the outputs have been shutdown:

1. The output current of one or more individual output channels was too high. In this case, the affected output channel LED is blinking and all others are illuminated.
2. The sum of the output current of all four output channels was exceeded. In this case, all red LEDs are blinking.
3. The outputs needed to be shutdown in order to maintain sufficient input voltage. In this case, all red LEDs are on and the green LED (Input Status) is blinking.

The outputs can also be turned off by pushing the ON/OFF button on the front of the unit or by applying an external signal to the ON/OFF signal input. In this case, all red LEDs are on.

When LED 1 and 4 as well as the LEDs 2 and 3 are alternately blinking, an internal error has occurred. Try to reset the unit by pushing the reset button. If this does not help, ship the unit to the factory for inspection.

C—ON/OFF and Reset Button

This is a pushbutton which can be used for two purposes:

1. In a failure mode (outputs have shutdown), the outputs can be turned on again by pushing and holding the reset button for more than 1 second.
2. In normal mode (outputs have not shutdown), a short (> 50ms) push will turn all outputs ON or OFF.

The unit will be shipped (factory setting) with the outputs turned-on. The ON/OFF function has no safety feature included.

D—Synchronization Bus (connection by plug-connector on the front).

If multiple Bulletin 1692 modules are used on the same power supply, it is recommended to connect the sync. bus of all modules together. If one unit shuts down due to the protection function of the input voltage protection circuit, all other modules will shutdown too. This avoids a false interpretation of which output channel caused the problem. If the cause for the shutdown was an over-current of one individual channel only this module will shutdown and the other modules will stay on. In this case the sync. line has no impact on the other modules.

E—Output-OK Relay Contact

Output-OK Relay Contact (connection by plug-connector on the front), This relay contact is closed when the input voltage is sufficient and all outputs are not shutdown.

F—Inhibit / Reset Signal Input (connection by plug-connector on the front) This signal input is galvanically isolated with an integrated optocoupler and works in the same manner as the reset and ON/OFF button. The ON/OFF function has no safety feature included.

1. In a failure mode (outputs have shutdown), the outputs can be turned on again by applying a voltage for more than 1 second.
2. In normal mode (outputs have not shutdown), a short (> 50ms) voltage Rockwell Automation will turn all outputs ON or OFF.

G—Green Input Status LED This LED indicates the status of the input. The green LED is illuminated if the input voltage is higher than 21Vdc. The green LED will blink when the input protection circuit (voltage monitor) is activated in order to protect the supply voltage from dropping below 21V or when the outputs have already been shutdown due to a low input voltage.

H—Input Terminals Two minus (-) connection points for simpler load distribution or grounding (earthing) of the minus (-) pole.

Please note: Outputs which have shutdown must be turned on manually by pushing the reset button or by an external reset signal (ON/OFF signal input). A cycling of the input power does not reset the unit. The failure signals are stored until a reset is intentionally initiated.

Terminals and Wiring

All terminals are easy to access when mounted on the panel.
Input, outputs and signal terminals are separated from each other to help in error-free wiring.

	Input and Output	Signals
Type	screw terminals	plug connector
Solid wire	0.2...6 mm ²	0.2...1.5 mm ²
Stranded wire	0.2...4 mm ²	0.2...1.5 mm ²
AWG (American Wire Gauge)	24...10 AWG	24...16 AWG
Wire stripping length	7 mm / 0.28 in	6 mm / 0.24in
Screwdriver	3.5 mm slotted or Pozidrive No 2	2.5 mm slotted
Recommended tightening torque	0.8 Nm, 7lbs.in	0.35Nm, 3lbs.in

Instructions:

- a) Use appropriate copper cables that are designed for minimum operating temperatures of:
60 °C for ambient up to 45 °C and minimum
75 °C for ambient up to 60 °C and minimum
90 °C for ambient up to 70 °C.
- b) Follow national installation codes and installation regulations!
- c) Ensure that all strands of a stranded wire enter the terminal connection!
- d) Up to two stranded wires with the same cross section are permitted in one connection point.
- e) Screws of unused terminal compartments should be securely tightened.
- f) Ferrules are allowed.

EMC

The Bulletin 1692 protection module is suitable for applications in industrial as well as in residential, commercial and light industrial environments without any restrictions (e-g- cable length). The CE mark indicates conformance with EMC guideline 2004/108/EC and the low-voltage directive (LVD) 2006/95/EC. A detailed EMC report is available on request.

EMC Immunity	Generic standards: EN 61000-6-1 and EN 61000-6-2				
			Outputs ON	Outputs OFF	
Electrostatic discharge	EN 61000-4-2	Contact discharge ① Air discharge	8kV 8kV	8kV 8kV	Criterion A Criterion A
Electromagnetic RF field	EN 61000-4-3	80MHz-2.7GHz	10V/m	10V/m	Criterion A
Fast transients (Burst)	EN 61000-4-4	Input lines output lines DC-OK, Inhibit	2kV 2kV 1kV	2kV 2kV 1kV	Criterion A Criterion A Criterion A
Surge voltage on input lines	EN 61000-4-5	+ → - +/- → DIN-Rail	500V 1kV	500V 1kV	Criterion A Criterion A
Surge voltage on output lines	EN 61000-4-5	+ → - +/- → DIN-Rail	500V 1kV	500V 1kV	Criterion A Criterion A
Surge voltage on signal lines	EN 61000-4-5	DC-OK, Inhibit → DIN-Rail	1kV	1kV	Criterion A
Conducted disturbance	EN 61000-4-6	0.15-80MHz	10V	10V	Criterion A

Criterion A: The Bulletin 1692 protection module shows normal operation behavior within the defined limits.

① On coupling plane

EMC Emissions	Generic standards: EN 61000-6-3 and EN 61000-6-4	
Conducted emission	IEC/CISPR 16-1-2, IEC/CISPR 16-2-1	Class B, DC input and DC-output
Radiated emission	EN 55011, EN 55022	Class A

Environment

Operational temperature ❶	-25°C ... +70°C (-13°F to 158°F)	for 1692-ZR1111, 1692-ZR2222, 1692-ZG3333 without de-rating
	-25°C ... +60°C (-13°F to 140°F)	for 1692-ZG4444, 1692-ZG6666, 1692-ZGAAAA, 1692-ZG3366, Bulletin 1692.206210 without de-rating
Output de-rating	+60°C ... +70°C (140°F to 158°F)	De-rate linearly to 15A between 60°C and 70°C for 1692-ZG4444, 1692-ZG6666, 1692-ZGAAAA, 1692-ZG3366, Bulletin 1692.206210, see also Figure 11.
Storage temperature	-40 to +85°C (-40°F to 185°F)	
Humidity ❷	5 to 95% r.H.	IEC 60068-2-30
Vibration	2-17.8Hz: ±1.6mm; 17.8-500Hz: 2g 2 hours / axis	IEC 60068-2-6
Shock	30g 6ms, 20g 11ms 3 bumps / direction, 18 bumps in total	IEC 60068-2-27
Altitude	0 to 6000m (0 to 20 000ft)	
Over-voltage category	III	IEC 62103, EN 50178, altitudes up to 2000m
	II	for altitudes from 2000m to 6000m
Degree of pollution	2	IEC 62103, EN 50178, not conductive

- ❶ Operational temperature is the same as the ambient temperature and is defined as the air temperature 2cm below the unit.
- ❷ Do not energize while condensation is present.

Figure 11: **Total module output current vs. ambient temperature**

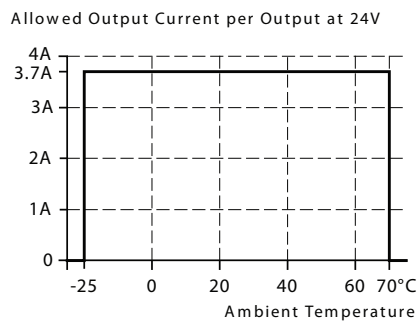

Protection Features

Output over-current protection	Electronically limited
Class of protection — IEC 61140	III
Degree of protection —EN/IEC 60529	IP 20
Penetration protection	> 2.5 mm in diameter
Over-temperature protection	Not included
Reverse polarity protection; input voltage ❶	Not included
Internal input fuse	Not included

❶ Make sure that the input voltage polarity is correct before applying the input voltage.

Dielectric Strength

The relay contact and the ON/OFF signal input are floating and have no ohmic connection to the input or output voltage. Type and factory tests are conducted by the manufacturer. The creepage and clearance distances between relay contacts, the ON/OFF signal input and input/output voltage are 1.3 mm. The following dielectric strength tests were conducted:



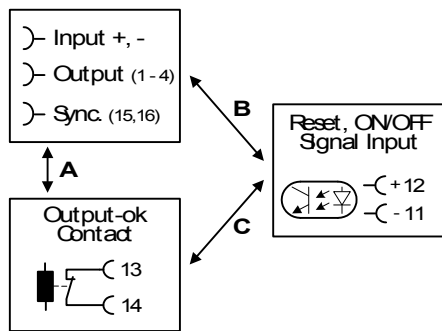

Figure 12: Dielectric strength



		A	B	C
Type test	60s	500Vac	500Vac	50Vac
Factory test	5s	500Vac	500Vac	-
Field test	5s	500Vac	500Vac	50Vac
Cut-off current setting		> 1mA	> 1mA	> 1mA

Type and factory tests are conducted by the manufacturer. Field tests may be conducted in the field using the appropriate test equipment which applies the voltage with a slow ramp (2s up and 2s down). Connect all input and output terminals together as well as all signal poles before conducting the tests. When testing, set the cut-off current settings to the value in the table above.

Approvals

EC Declaration of Conformity		The CE mark indicates conformance with EMC directive 2004/108/EC and the low-voltage directive (LVD) 2006/95/EC.
IEC 60950-1 2nd Edition		CB Scheme, Safety of Information Technology Equipment
UL 508		Listed for the use as Industrial Control Equipment; U.S.A. (UL 508) and Canada (C22.2 No. 107-1-01); E-File: E56639
UL 60950-1 2nd Edition		Recognized for the use as Information Technology Equipment, Level 5; U.S.A. (UL 60950-1) and Canada (C22.2 No. 60950) ; E-File: E168663
NEC Class 2	NEC CLASS 2	Listed as Limited Power Source (LPS) in the UL 60950-1 UL report. According to NEC (National Electrical Code) Article 725-41 (4).
UL 2367		Special-purpose Solid-State Overcurrent Protector Component Recognition; UL Category QVRQ2 E-File: E350272

Fulfilled Standards

EN/IEC 60204-1	Safety of Electrical Equipment of Machines
EN/IEC 61131-2	Programmable Controllers
EN 50178, IEC 62103	Electronic Equipment in Power Installations

Used Substances

The unit does not release any silicone and is suitable for the use in paint shops.
The unit conforms to the RoHS directive 2002/95/EC.
Electrolytic capacitors included in this unit do not use electrolytes such as Quaternary Ammonium Salt Systems.
Plastic housings and other molded plastic materials are free of halogens.
Wires and cables are not PVC isolated.
The production material within our production does not include following toxic chemicals: Polychlorized Biphenyl (PCB), Polychlorized Terphenyl (PCT), Pentachlorophenol (PCP), Polychlorinated naphthalene (PCN), Polybrom Biphenyll (PBB), Polybrom Bipheny-oxyd (PBO), Polybrominated Diphenylether (PBDE), Polychlorinated Diphenylether (PCDE), Polydibromphenyl Oxyd (PBDO), Cadmium, Asbestos, Mercury, Silicia.

Physical Dimensions and Weight

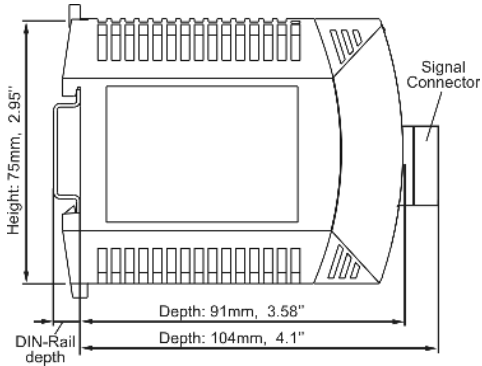
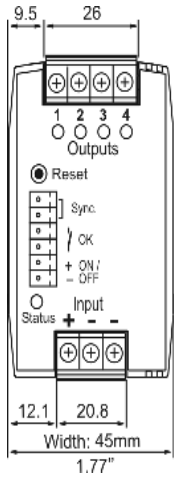

Weight	120g / 0.26lb
DIN-Rail	Use 35 mm DIN-rail according to EN 60715 or EN 50022 with a height of 7.5 or 15 mm. The DIN-rail height must be added to the unit depth to calculate the total required installation depth.

www.rockwellautomation.com

Power, Control and Information Solutions Headquarters

Americas: Rockwell Automation, 1201 South Second Street, Milwaukee, WI 53204 USA, Tel: (1) 414.382.2000, Fax: (1) 414.382.4444

Europe/Middle East/Africa: Rockwell Automation, Vorstlaan/Boulevard du Souverain 36, 1170 Brussels, Belgium, Tel: (32) 2 663 0600, Fax: (32) 2 663 0640

Asia Pacific: Rockwell Automation, Level 14, Core F, Cyberport 3, 100 Cyberport Road, Hong Kong, Tel: (852) 2887 4788, Fax: (852) 2508 1846