

# Circuit Protection Methods

## *Differentiating between Supplementary Protection, Branch Circuit Protection, and Self-Protected Devices*

### Introduction

Modern electrical equipment continues to increase in complexity and importance in industrial, commercial, and residential installations. This equipment is often considered critical for normal system operations. As such, the importance of circuit protection and overall equipment protection continues to increase and is an important topic to understand.

Determining whether a circuit is adequately protected can require a high-level view of the electrical distribution system, from the fault current available at the source of supply down to the end device connected in the system. Circuit protection includes protection from equipment overload conditions, undervoltage and overvoltage conditions, ground faults, and short circuits. Although mandated by code for any electrical installation, the proper implementation of circuit protection products can be confusing at times. Occasionally this confusion results in circuit protection products that are installed in circuits where their use is not appropriate.

From a machinery design standpoint, system engineers and equipment designers must choose appropriate protective devices to maintain the safety and reliability of their products. Circuit protection devices protect expensive systems by rapidly disconnecting power to components in the event of an abnormal operating condition. Even though guidance exists in the form of the various electrical codes, the wide variety of product offerings can make the proper selection of circuit protection devices a challenge. An understanding of circuit types and circuit protection products is critical to achieving their proper application. Products that are addressed in this white paper include circuit breakers made in accordance with UL 489<sup>1</sup>, supplementary protectors made in accordance with UL 1077<sup>2</sup>, and manual motor controllers as defined in UL 508<sup>3</sup>. Application and product use is explained as suitable for North American installations.

### History

In the United States, the National Electric Code (NEC) exists to guide electricians in the proper installation of electrical equipment and defines the specific requirements for circuit protection.<sup>5</sup> The focus of the NEC, which is a code that is developed by the National Fire Protection Association (NFPA 70), is primarily fire prevention. Circuit protection is required to help prevent fires from occurring due to overcurrent faults or short circuits. In Canada, the Canadian Electric Code (CEC) exists to provide similar guidance. Other areas of the world have equivalent country or local codes. In Europe, IEC is the most familiar guiding organization, but there is also VDE of Germany, KEMA of the Netherlands, and SEMKO of Sweden. Each of the regulatory bodies or testing agencies can be recognized as the guiding body for a specific geographical area. They define performance criteria and proper use of electrical equipment and components in a given location. More importantly, they provide independent verification of manufacturers' self-certification of products to the various IEC standards.

Much of the confusion that is associated with proper application of circuit protection products is related to product use in North American markets. History has shown that there is a certain amount of confusion and misunderstanding regarding the meanings and proper application of circuit breakers, supplementary protectors, circuit breakers for equipment, and branch circuit protection devices. Some of this confusion is related to the look and function of these devices and the differences in how they can be applied in other areas of the world. It is not uncommon for non-US/ Canada-manufactured equipment coming into the US or Canada to be red-tagged by UL or CSA inspectors because it does not meet the North American circuit protection requirements.

The different codes for the United States, Canada, and the rest of the world have corresponding and unique definitions for circuit breakers. A circuit breaker's primary function is to protect wire. In North America, the term 'circuit breaker' generally refers to a device that is a UL 489 / CSA 22.2 No. 5 constructed device. In other parts of the world, there are other guidelines for circuit breaker definition. Differences between UL, CSA, and IEC codes reflect the differences in technical definition from country to country. As a result, items that are categorized as IEC circuit breakers (miniature circuit breakers or circuit breakers for equipment) do not always comply with the UL or CSA standards. Miniature circuit breakers are common in IEC marketplaces, but in North America these devices are normally referred to as supplementary protectors.

This document focuses on North American applications, which are governed by the NEC and CEC.

## Definitions

The following definitions are based on the UL standards: UL 4891, UL 10772, UL 5083 and UL 508A4, and NFPA 705 (NEC2008). They are provided here as a reference.

**Table 1 - Terms and Definitions**

Term	Definition
<b>Available Fault Current (AFC)</b>	The current in a circuit that would flow if a short circuit of negligible impedance were to occur at a given point.
<b>Branch Circuit</b>	The conductors and components following the last overcurrent protective device protecting a load.
<b>Branch Circuit Protection</b>	Overcurrent protection with an ampere rating that is selected to protect the branch circuit. For a motor branch circuit, the overcurrent protection is required for overcurrents due to short circuits and faults to ground only.
<b>Branch Circuit Protective Device</b>	A fuse or circuit breaker that has been evaluated to a safety standard for providing overcurrent protection.
<b>Circuit Breaker</b>	A device that is designed to open and close a circuit by non-automatic means, and to open the circuit automatically on a pre-determined overcurrent, without damage to itself when properly applied within its rating. In the US, the device must have an approval to UL 489. In Canada, the device must be approved to CSA 22.2 No. 5. In IEC regions, the approval is to either IEC 60 898 or IEC 60 047-2
<b>Class 1 Circuit</b>	A control circuit on the load side of overcurrent protective device where the voltage does not exceed 600V, and where the power available is not limited, or control circuit on the load side of power limiting supply, such as a transformer.
<b>Class 2 Circuit</b>	A control circuit that is supplied from a source having limited voltage (30V rms or less) and current capacity, such as from the secondary of a Class 2 transformer, and rated for use with Class 2 remote-control or signaling circuits.
<b>Control Circuit</b>	A circuit that carries the electric signals directing the performance of a controller, and which does not carry the main power circuit. Often, a control circuit is limited to 15 A.
<b>Control Circuit Transformer</b>	A transformer whose secondary supplies power to control circuit devices only (excluding loads).
<b>Interrupting Rating</b>	The highest current, at rated voltage, that a device is intended to interrupt under standard test conditions.
<b>Let-through Current</b>	The maximum instantaneous or peak current that passes through a protective device.
<b>Manual Motor Controller (with disconnect rating)<sup>(1)</sup></b>	An electrical device suitable for the switching on and off of motor loads. Manual motor controllers must meet the requirements of UL 508, pass the additional dielectric voltage withstand test (specified in UL 508) following the appropriate short circuit test in that standard, and pass the extended mechanical operations test as specified in the endurance test of UL 508. Manual motor controllers that carry a motor disconnect rating must be marked "suitable as motor disconnect". For a motor disconnect rating, the operating means of a manual motor controller shall be provided with a method of being locked in the off position.
<b>Miniature Circuit Breaker (MCB)</b>	Originally this term was for a product that met the requirements of IEC 60 898 or IEC 60 947-2, was DIN rail mounted and no wider than 25 mm per pole. Today MCBs can also refer to devices that also meet North American standards such as UL 489, UL 1077, CSA 22.2 No. 5, and No. 235. Given that broad scope it is important to understand the intended application requirements and regional standard that is required.

Term	Definition
<b>Molded Case Circuit Breaker (MCCB)</b>	Originally this term was for a product that was manufactured from a molded material and intended that all (electrical) moving parts were contained within the housing as opposed to an Air Circuit Breaker (ACB) where the (electrical) moving parts are not contained within an enclosure. In the US, the devices conform to UL 489, in Canada conformation is to CSA 22.2 No 5, in IEC regions the standard is based on IEC 60 947-2.
<b>Supplementary Protection</b>	A device, typically either a supplementary fuse, or a supplementary protector (see below), intended to provide additional protection subsequent to branch circuit protection. This device has not been evaluated for providing branch circuit protection. The purpose of supplementary protection is to provide additional protection for a given piece of electrical equipment - it does not serve as branch circuit protection. Supplementary protection can be provided by fuse (rated as supplementary protection) or by a supplementary protector.
<b>Supplementary Protector</b>	A manually resettable device that is designed to open the circuit automatically on a pre-determined value of time versus current or voltage, within an appliance or other electrical equipment. It can also be provided with manual means for opening or closing the circuit. The primary function of a supplementary protector is to protect equipment. Supplementary protectors can be applied at 100% of the rated current values, in contrast with branch circuit breaker which is applied at 80% of the rated current value, unless marked differently on the device.
<b>Self-Protected</b>	A qualifying term that is applied to a controller that contains coordinated overload and short circuit protection. A self-protected controller is evaluated as a complete unit whether comprised of a single or multiple components. Coordinated protection is able to be inherent or obtained by correct selection of components or accessory parts in accordance with the manufacturer's instructions.
<b>Withstand Rating</b>	The maximum current that an unprotected electrical component can sustain for a specific period without the occurrence of extensive damage.

(1) Per the definitions of the NEC (and CEC) and UL/CSA, a branch-circuit inverse-time circuit breaker is permitted as a controller for all motors. (NEC 430.83.A.2)

## Standards

In the United States, there are three basic categories for circuit protective devices as they relate to this document: UL 489, UL 1077, and UL 508. An additional category, which is a subset within UL 508 that defines self-protected (Type E) devices, are added for discussion. The Canadian equivalent standards are CSA 22.2 No. 5, CSA 22.2 No. 235, and CSA 22.2 No. 14. This document attempts to explain the differences between products that are tested and rated to these standards, and describe their applicability in field installations.

### UL 489 - Circuit Breakers

A definition for what a circuit breaker is depends primarily on your location in the world. A general circuit breaker definition from UL is, 'a device designed to open and close a circuit by manual means, and to open a circuit automatically on a pre-determined overcurrent, without damage to itself when properly applied within its rating'.<sup>1</sup> But this UL definition is open to interpretation. For clarification, *in the United States, a circuit breaker is a device constructed to and performing in accordance with UL standard 489.* UL 489 devices are recognized as providing branch circuit protection. In Canada, CSA 22.2 No. 5 provides equivalent design and performance guidance.

UL 489 is the standard that defines products often identified as molded-case circuit breakers (MCCBs).<sup>1</sup> It also addresses molded-case switches (MCSs) as well as circuit breaker enclosures (CBEs). Molded-case circuit breakers are specifically intended to provide service entrance, feeder, and branch circuit protection in accordance with the NEC. Molded case circuit breakers that are built to the UL 489 standard, also meet the requirements of CSA 22.2 No. 5. They can be used as service feeder or branch circuit protective devices. As circuit breakers, they can provide motor branch circuit protection and can be used as a disconnecting means. The branch circuit protection is applied at no more than 80% of the continuous current values unless marked for 100% current ratings. This is in contrast with supplementary protectors which may be applied up to 100% of the rated current.

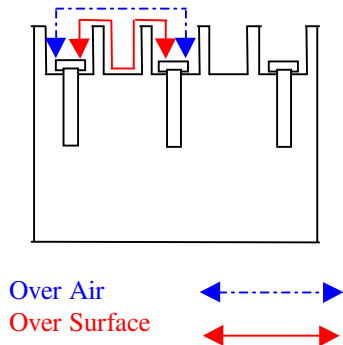
**Figure 1 - Over Air and Over Surface Spacing Between Conductors**

Historically, product size is one of the differentiating factors between UL 489, UL 1077 and UL 508. Generally, UL 489 devices were relatively large in physical size due to the spacing requirements dictated by the standard, and historically did not have current ratings below 15 A for installations up to 600V AC. The large spacing between conductors, 1 inch through air and 2 inches over surface, meet UL and NEC requirements for service entrance applications.

UL 489 allows for smaller spacings at voltages below 300V. Some of these UL 489 products are now being produced with voltage limits in the 240V AC range. UL 489 circuit breakers, which are used up to the 600V AC level, are commonly found with Available Fault Current (AFC) ratings in the 50...100 kA range or higher. This means that they are capable of breaking a circuit whose source of supply could deliver fault currents up to those levels.

Today UL 489 devices are readily available in specific voltage ranges and with current ranges below 15 A, allowing closer sizing between load and protection.

UL 489 circuit breakers up to 600V may not be current limiting, meaning that when they trip, they rely upon the zero-crossing characteristics of the current waveform for complete circuit interruption. Under these conditions, the let-through energy can be quite high and components affected by the fault, which might include a critical load, will be subject to a high level of electrical energy.

As a branch circuit protection device, UL 489 circuit breakers are tasked with protection of the circuit wiring. Their purpose is to help prevent electric shock and fire, and to provide a means for electrical isolation during maintenance periods. A key point to note here is that they do not necessarily, but may, serve as protection for the connected electrical load.

## UL 1077 - Supplementary Protectors

Supplementary protectors are another circuit breaker type of device which is built to comply with UL 1077. As the name implies, supplementary protectors serve to supplement the circuit protection that is already in place. Where UL 489 devices are tasked with conductor protection, protection of the load is the primary purpose of selecting a UL 1077 device. They are circuit breaker type devices because their function meets the definition of a circuit breaker, even though they are not categorized as circuit breakers in US and Canadian markets. One key difference between circuit breakers and supplementary protectors is the physical size of the device. UL 1077 spacings for applications up to 600V AC are 3/8 inch through air and 1/2 inch over surface. These smaller spacings allow for a smaller product to be produced, but also impose some restrictions on how the product can be used. Whereas UL 489 devices can have AFC ratings in the 50...100 kA range or higher, supplementary protectors generally have AFC ratings of 10 kA or less. Supplementary protectors are not branch circuit protective devices because they are not recognized by UL or CSA as providing conductor short circuit protection. As stated earlier, protection of the *load* is one of the primary purposes for selecting a supplementary protector.

The Canadian standard for supplementary protectors is CSA 22.2 No. 235. CSA states that supplementary protectors are, "...intended to be components *within an appliance or other electrical equipment*."<sup>6</sup> These devices are purposely intended to be *tailored to the overcurrent protection requirements of a specific load* and application.

Supplementary protectors can provide various types of protection. They can be used as overcurrent, overvoltage, or undervoltage protection within an appliance or other electrical equipment. The supplementary devices that are addressed in this document are overcurrent protection devices. These devices can be used as long as branch circuit overcurrent protection is already provided or is not required. The supplementary protector must be suitable for continuous use under the conditions that are seen in actual service. These conditions include the inrush current of the device being protected, circuit voltage, continuous current in the circuit, and other operating conditions. Therefore, individual applications may need special review to determine if the supplementary protector is affected by the design of the equipment in which it is used. Acceptable use of the supplementary protector is determined by the conditions that are found in its actual installation.

Suitability of the supplementary protector is dependent on other components in the installation. A sample of these components and related items to consider include: the ratings and types of upstream protection, transformer sizes and their deliverable currents in a fault condition, conductor impedances and lengths, and characteristics of the connected load. A review at the system level, not at the individual component level, is required for proper product selection.

Neither CSA nor UL identifies a specific requirement for an interrupt capacity for supplementary protectors. However, most manufacturers do identify a component interrupt capability, identified by the published short circuit current rating in UL's recognized component directory (yellow card data at <http://www.ul.com/plastics/flame.html>). It is important to note that the manufacturer selects the criteria by which the product will be tested, and that there are several variations of the short circuit current rating qualification. For example, the Allen-Bradley Bulletin 1492-SPM has up to 10 kA interrupt capability at 480Y/277V AC, with an SC code of U2 (tested without additional series overcurrent protection and passing re-calibration after the short circuit test). It is important to note that neither US nor Canadian installations allow the interrupt capability of the supplementary protector to be used to meet the code requirements for branch circuit protection in a given installation. The load must have short circuit protection available from some other circuit component located upstream of the supplementary protector to provide the branch circuit protection. Supplementary protectors must not be installed in installations where their interrupt ratings are exceeded.

Some circuit breakers and supplementary protectors provide the added benefit of current limitation. A current-limiting device is capable of providing enhanced protection beyond that of a conventional device. A current-limiting device does not rely upon the zero crossing of the current waveform and can be faster acting than a conventional device, therefore limiting the electrical energy seen during a fault condition.

As shown in Figure 2, the current-limiting function of a fast acting circuit breaker significantly reduces the let-through current seen in the event of a short circuit fault. This benefits the electrical system by reducing the electrical energy that attached equipment and components can be exposed to if a fault occurs. Generally, let-through energy of a current limiting supplementary protector is reduced to a level of 1/10th or less of that experienced when using a device relying on the zero-crossing current characteristics.

**Figure 2 - Difference in let-through current between a current limiting breaker and non-current limiting breaker**

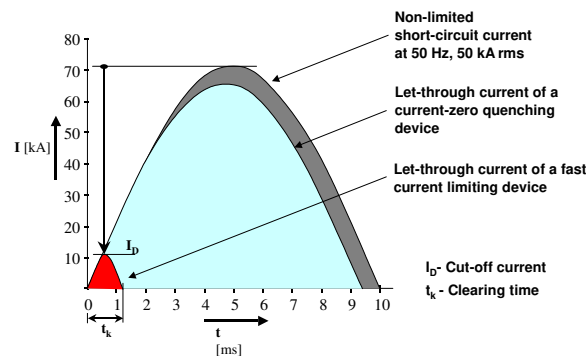

## Differences Between Circuit Breakers and Supplementary Protectors

Using a residential example may show the differences between a circuit breaker and a supplementary protector. In most homes there is a circuit breaker box (or fuse box) that is used to protect the wiring within the house. Typically most of the circuit breakers are 15 or 20 A and the wire is sized to be protected by those circuit breakers.

In many homes, the kitchen sink contains a garbage disposal. If you put too much into the disposal, the disposal stops working. When you allow the disposal to cool and then press a reset button on the disposal, the disposal will work again.

This button is a reset of a supplementary protector incorporated into the disposal. The supplementary protector provides additional protection for the disposal, in addition to the branch circuit protection provided in the centralized location. Typically, that protector is about one (1) or two (2) amps to provide protection for the motor in the disposal. If the 15 A allowed by the wiring protection from the centralized circuit breaker were to flow to the disposal, the disposal motor may be destroyed. The supplementary protector provides:

- Equipment protection of the motor
- Local protection near (on) the disposal
- Isolation of the individual load
- Is in addition to the wire protection of the house wiring

In the same manner in North American industrial equipment, branch circuit protection is used to provide wire protection and supplementary protectors are used to provide equipment protection.

## All Supplementary Protectors are Not Equal

The UL 1077 standard allows for several levels of testing for products identified as supplementary protectors. Each manufacturer may specify the capability of the supplementary protector products within some guidelines. A sample of tabulated data taken from UL's recognized component directory for some Allen-Bradley supplementary protectors is shown below. There are several categories that are identified to establish appropriate use for supplementary protectors, which include: Use Group (UG), Terminals (FW), Maximum Voltage (Max V), Maximum Amperage (Max amps), Tripping Current (TC), Overload Rating (OL), and short circuit Current Rating (SC).

**Table 2 - Rating Descriptions**

<b>Type</b>	OC - Overcurrent UV - Undervoltage SPV - Shunt protector, voltage	OV - Overvoltage SPOC - Shunt protector, overcurrent
<b>Use Group</b>	A - General Industrial B - Household Kitchen Appliances	C - Household Appliances D - Commercial Appliances
<b>Terminals</b>	0 - Suitable for Factory Wiring Only 1 - Line Terminals Evaluated for Field Wirings	2 - Load Terminals Evaluated for Field Wiring 3 - Line and Load Terminals Evaluated for Field Wiring
<b>Max Volts</b>	Identifies the maximum (50/60 Hz) voltage at which the protector has been tested.	
<b>Max Amps</b>	Identifies the amperage rating for the protector or family of protectors.	
<b>Tripping Current</b>	0 - Tripping Current is less than 125% of the Amp rating 1 - Tripping Current is 125...135% of the Amp rating 2 - Tripping Current is more than 135% of amp rating 3 - Tripping Current and Time is standardized at 135% and at 200% of amp rating	
<b>Overload Rating</b>	0 - Tested at 1.5 times the amp rating for general use 1 - Tested at 6 times the AC amp rating or 10 times the DC amp rating for motor starting	
<b>SC Rating</b>	C - Indicates that the Short Circuit test was conducted with series overcurrent protection U - Indicates that the Short Circuit test was conducted without series overcurrent protection 1 - Indicates that a re-calibration was not conducted as part of the Short Circuit testing 1a - Indicates that the protector was permanently open after the Short Circuit test; and dielectric strength and voltage withstand tests were performed after the Short Circuit testing 2 - Indicates that a re-calibration was performed as part of the Short Circuit testing 3 - Indicates that the protector was proven to be suitable for further use after the Short Circuit test; re-calibration, dielectric strength and voltage withstand tests were performed after the Short Circuit test	

**Table 3 - Ratings By Supplementary Protector**

Cat. No.	Type	UG	FW	Max Volts	Max Amps	TC	OL	SC
1492-GS	OC	B,D	3	277/480V AC	0.2...16	2	0	5.0 kA, C1
1492-GS	OC	B,D	3	277/480V AC	18...25	2	0	2.0 kA, C1
1492-GHxxx	OC	A,C	0	250V AC, 80V DC	0.2...15	2	0	200 A, C1
1492-SPM	OC	A,C,D	3	480Y/277V AC, 96V DC	0.5...63	1	0	(1)

(1) See pole arrangements below.

**Table 4 - Ratings By Pole Arrangement**

Pole Arrangements (1)	Type	UG	FW	Max Volts	Max Amperes	TC	OL	SC
1 pole	OC	A, C, D	3	277V AC	0.5...32	1	0	10 kA,U2
	OC	A, C, D	3	277V AC	35...63	1	0	5 kA,U2
	OC	A, C, D	3	48V DC	0.5...63	1	0	10 kA,U2
1 pole+N	—	—	—	230V AC	0.5...40	—	—	—
2, 3, 4 pole	OC	A, C, D	3	480Y/277V AC	0.5...35	1	0	10 kA,U2
	OC	A, C, D	3	480Y/277V AC	40...63	1	0	5 kA,U2
3 pole+N	—	—	—	480Y/277V AC	0.5...35	—	—	—
2 poles in series	OC	A, C, D	3	96V DC	0.5...40	1	0	10 kA,U2

(1) Neutral poles are not UL or CSA certified.

**Auxiliary contacts:** Models 189-AR3, -AR11, AR02, -AR20, AL11, AL02, AL20, -AB01, -AB10

**Shunt trips:** Models 189-AST1, AST2

**Signal contact:** Models 189-ASCR3

**Marking:** Company name or trademarks catalog or model designation.



**Rockwell  
Automation**

All of the observed categories are important, but probably the most significant difference is in the area of the Short Circuit test rating. When comparing supplementary protectors, the Short Circuit withstand rating, suitability for further use (re-calibration verification) and test success without a series fuse are significant performance differentiators. Devices that are recognized as passing the Short Circuit test without a series fuse have greater application flexibility than products that require a series fuse to pass the same tests.

**IMPORTANT** The installation examples in this document assume an SC rating of U2, which has been achieved by the Bulletin 1492-SPM series of Allen-Bradley products.

Application of supplementary protectors in UL 508A industrial control equipment generally is included in the equipment's procedures, describing the method of use and selection.

## UL 508 - Industrial Control Equipment

UL 508 is the standard which defines the requirements for industrial control devices and their accessories.<sup>3</sup> Devices recognized as UL 508 components are intended to be used for starting, stopping, regulating, controlling, or protecting *electric motors and industrial equipment*. Equipment covered by UL 508 is for use in *ordinary* locations in accordance with NFPA 70 of the National Electrical Code.<sup>5</sup> These requirements also cover industrial control panels that are assemblies of industrial control devices and other devices associated with the control of motor operated and related industrial equipment. Examples of devices in an industrial control panel are industrial control devices, disconnecting means, motor branch circuit protective devices, temperature control devices, and electrical instruments. The spacing requirements for UL 508 are the same as UL 1077, which are 3/8 inch through air and 1/2 inch over surface for applications up to 600V AC. There are numerous examples of industrial control devices, such as motor starters, push button stations, control circuit switches and relays, proximity switches, programmable controllers, PLC outputs, etc.

### UL 508 Type E Self-Protected Devices

As defined in UL 508, a Type E self-protected combination motor controller can serve the function of a disconnect, branch circuit protection, motor disconnect, and motor overload self-protected device.<sup>3</sup> This combined rating eliminates any additional requirements for upstream fuses or devices circuit breakers in installations utilizing a Type E device. Type E devices are generally used in an installation where several motor controllers are found in a common panel. Because of their component size and multiple functions, Type E devices are increasing in popularity. When compared to traditional group motor installations, Type E devices simplify the installation because the requirement for the group fusing is eliminated. There are some additional requirements of a self-protected motor controller for its proper use. A Type E device must have a method of being locked in the off position. All ungrounded supply conductors must be broken when the device opens the circuit and the device must not be capable of independently breaking a single pole under normal service conditions. Because it provides protection for both Short Circuit and overload conditions, a Type E combination motor controller must visibly indicate and differentiate which function, overload or Short Circuit, has occurred.

The field wiring terminals on the line side of a Type E combination motor controller are required to have the same spacings required in UL 489, which are 1 inch through air and 2 inches over surface. These spacings make the device suitable for installations up to 600V AC. The self-protected rating provides protection for itself, the connected load, and the conductors between the Type E device and the load. Additionally, some self-protected devices are suitable for tap protection as allowed in NEC 430-53(D)(3). This greatly expands installation flexibility by increasing the NEC allowable tap conductor ampacity ratio.

### UL 508A - Industrial Control Panels

UL 508A is the standard which defines the requirements for the assembly of industrial control panels (and related panels) intended for general industrial use, operating from a voltage of 600 volts or less. This equipment is intended for installation in ordinary locations, in accordance with the National Electrical Code, ANSI/NFPA 70, where the ambient temperature does not exceed 40 °C (104 °F) maximum.

This equipment consists of assemblies of two or more power circuit components, such as motor controllers, overload relays, fused disconnect switches, and circuit breakers, or control circuit components, such as push buttons, pilot lights, selector switches, timers, and control relays, or a combination of power and control circuit components, with associated wiring, and terminals. These components are mounted on, or contained within, an enclosure, or are mounted on a sub-panel.

---

## Circuit Types

Circuit type plays a considerable role in determining what type of circuit protection device can be utilized. There are basically 3 main circuit types: feeder, motor branch, and control. Control circuits are further broken into 2 sub-categories; class 1 control circuits, up to 600V and class 2 energy limited control circuits, up to 30V. Application of circuit breakers, supplementary protectors, and self-protected devices is very much related to circuit type. The following diagram will help identify each of these circuit types.

**Figure 3 - Circuit Protection Devices**

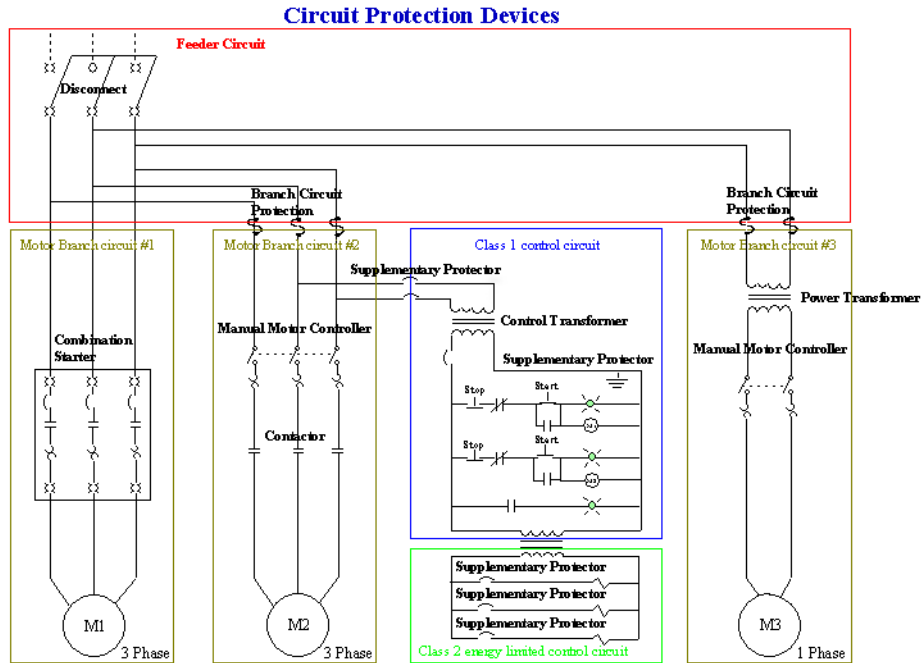

## Codes: NEC / CEC

A key element of this document is identification of the proper use of supplementary protectors. Information on how they can be applied in accordance with the various North American codes will be discussed next. Supplementary protectors are addressed in the NEC, but only with regard to motor control circuit overcurrent protection<sup>1</sup>. Supplementary protectors are specifically allowed within the NEC, where the motor control circuit is tapped from the load side of the motor branch circuit protection device, as shown. Other acceptable uses of supplementary protectors will be addressed later in this document.



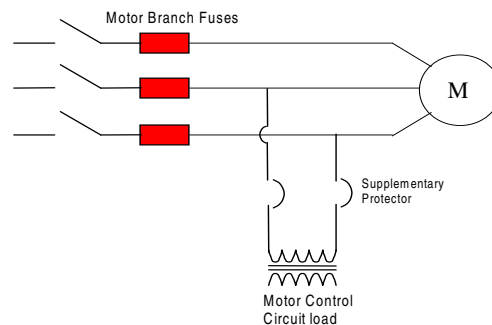

**Figure 4 - Motor Branch Circuit Device**



## Allen-Bradley Product Portfolio

The Allen-Bradley portfolio of products has many solutions that can be used to provide various degrees of circuit protection. This list and set of descriptions covers some of the available product offerings.

**Table 5 - Product Offering and Descriptions**

	<p><b>1489-M</b></p> <ul style="list-style-type: none"> <li>• The circuit breaker is for branch circuit protection</li> <li>• Available in 1-, 2-, and 3-pole construction, they are rated 0.5...63 A at 240V AC and 0.5...40 A at 480Y/277V AC for North American applications (UL 489 and CSA C22.2 No. 5)</li> <li>• The 1-pole circuit breaker also has a 1-pole 48V DC rating</li> <li>• The 2-pole (series) also has a 96V DC rating</li> <li>• Products up through 20 A have an SWD rating for switching florescent lighting loads</li> <li>• The product range all have HACR ratings for use on heating and air conditioning loads</li> <li>• Short circuit ratings are 10 kA</li> <li>• For ENIEC applications the products are rated 230/400V AC, 96V DC 0.5...63A, 15 kA</li> </ul>
	<p><b>1492-D</b></p> <ul style="list-style-type: none"> <li>• Similar in construction to the 1492-SPM circuit breaker with the addition of a permanent magnet, used to force the breaker opening arc into the arc splitters, allowing a rapid disconnection of the circuit</li> <li>• Available in 250V DC, 1-pole and 500V DC, 2-pole ratings only</li> <li>• Plus and minus polarity that must be observed</li> <li>• Short circuit ratings are 10 kA</li> <li>• UL 1077 DC rated circuit breaker</li> <li>• IEC ratings for the device is 1-pole 250V DC, 2-pole (series) 500V DC</li> </ul>
	<p><b>1492-SPM</b></p> <ul style="list-style-type: none"> <li>• A UL 1077 supplementary protector which also meets the requirements of CSA 22.2 No. 235</li> <li>• Available in 1-, 2-, or 3-pole configurations and can be applied at 480Y/277V AC</li> <li>• 1-pole plus neutral and 3-pole plus neutral configurations available</li> <li>• There are 3 trip classes available: <b>B</b> (3...5 <math>I_n</math>), <b>C</b> (5...10 <math>I_n</math>), and <b>D</b> (10...20 <math>I_n</math>),</li> <li>• Current ranges from 0.5 A...63 A</li> <li>• The North American AFC rating is up to 10 kA as a UL 1077 supplementary protector</li> <li>• IEC rated as a Miniature Circuit Breaker and as such provide wire protection to the IEC standards as well as equipment protection</li> <li>• The IEC voltage range: 230/400V AC</li> <li>• An AFC of 15,000 A to the IEC requirements (IEC 60 947-2)</li> </ul>
	<p><b>1492-FB</b></p> <ul style="list-style-type: none"> <li>• A UL 512 and CSA 22.2 fuse holder</li> <li>• Depending on the catalog number selected, it holds class J (30 A or 60 A size), CC, or midget style fuses</li> <li>• Type CC and type J fuses can be used to provide branch circuit protection</li> <li>• Midget style fuses (1 1/2 x 13/32 in. -10.3 mm x 38 mm) can be used to provide supplementary protection</li> <li>• Optional blown fuse indicator which allows easy troubleshooting of electrical circuits</li> </ul>
	<p><b>140M</b></p> <ul style="list-style-type: none"> <li>• This is a UL 508 Type E self-protected motor controller</li> <li>• 3-pole device with adjustable overload ranges</li> <li>• There are 2 Short Circuit tripping characteristics (13x <math>I_n</math> and 20x <math>I_n</math>)</li> <li>• Product range from 0.1 A...45</li> <li>• The AFC ratings are up to 65 kA</li> </ul>

	<p><b>140G</b></p> <ul style="list-style-type: none"> <li>• UL 489 Listed circuit breaker (also CSA 22.2 No. 5) that can provide branch circuit protection as required for UL and NEC requirements</li> <li>• The Short Circuit tripping characteristics are as required by UL within the standard</li> <li>• Product range is from 15... 1200 A in various frame sizes</li> <li>• The North American voltage range is to 600V AC.</li> <li>• Meet CSA 22.2 No. 5 standards for application requirement of the CEC.</li> <li>• Meet the IEC 60 947-2 standard for Circuit Protection and have approvals from KEMA-KEUR</li> <li>• IEC voltage range is to 690V AC</li> <li>• AFC ratings of up to 100,000 AIC (voltage dependent) are available</li> </ul>
	<p><b>1492-MC</b></p> <ul style="list-style-type: none"> <li>• A UL 489 circuit breaker that can provide branch circuit protection as required for UL and NEC requirements</li> <li>• Product range is from 10... 100 A</li> <li>• The North American voltage range is primarily to 120/240V AC and 240V AC</li> <li>• Meet CSA 22.2 No. 5 standards for application requirement of the CEC</li> <li>• AFC ratings are 10,000 AIC</li> <li>• Products up through 20 A have an SD rating for switching florescent lighting loads</li> <li>• Full line has HACR ratings for use on heating and air conditioning loads</li> </ul>
	<p><b>1492-MC with GFCI or GFEP.</b></p> <ul style="list-style-type: none"> <li>• Versions of the 1492-MC product line are available with Ground Fault Sensing circuits at 5 mA for personal protection (GFCI) to UL 943 and sensing at 30 mA for Equipment Protection (GFEP) to UL 1053</li> <li>• They do not carry IEC ratings</li> <li>• 1-pole and 2-pole devices rated at 120/240V AC</li> </ul>
	<p><b>1492-RCDA</b></p> <ul style="list-style-type: none"> <li>• Residual current detector that is designed to provide earth leakage (Ground Fault) detection to the requirements of UL 1077</li> <li>• Tested to 480V/277V AC with sensitivity at 30 mA, 100 mA, 300 mA, and 500 mA</li> <li>• Two pole and four pole versions are available</li> <li>• Known (in IEC terms) as an RCD or RCCB</li> <li>• The are generally applied with one or more Miniature Circuit Breaker(s)</li> <li>• IEC rated at 230/400V AC</li> </ul>
	<p><b>1492-GS</b></p> <ul style="list-style-type: none"> <li>• UL 1077 supplementary protector which also meets CSA 22.2 No. 235 requirements</li> <li>• 1-, 2-, or 3-pole devices with ranges from 0.2... 25 A</li> <li>• The AFC rating is up to 5 kA with a series overcurrent protector in place</li> <li>• For use in control circuit secondaries</li> </ul>
	<p><b>1492-GH</b></p> <ul style="list-style-type: none"> <li>• UL 1077 supplementary protector, which also meets CSA 22.2 No. 235 requirements</li> <li>• Single-pole devices with ranges from 0.2... 15 A</li> <li>• The AFC rating is up to 2 kA with a series overcurrent protector in place</li> <li>• For use in control circuit secondaries</li> </ul>

Article 240-10 of the NEC states the following regarding supplementary overcurrent protection, "Where supplementary overcurrent protection is used for lighting fixtures, appliances, and other equipment or for internal circuits and components of equipment, it shall not be used as a substitute for branch circuit overcurrent devices or in place of the branch circuit protection specified in Article 210.<sup>5</sup> This clearly indicates that supplementary protectors simply supplement branch circuit protection and that they are not a substitute for branch circuit protection.

## Typical Installations

It was previously stated that supplementary protectors are used to provide more precise protection to a given load. But it is also necessary to confirm that they are appropriate for use in the installation. Some types of loads are specifically prohibited from having a supplementary protector as the protective component. Supplementary protectors may not be applied as a motor branch, or branch circuit protection devices in either the US or Canada. Motor branch circuits may be protected by UL 489 devices, UL 508 devices in combination with a Short Circuit protective device, or UL 508 Type E self-protected devices.

Supplementary protectors are specifically targeted at protecting control circuits, including some of the following types of loads: solenoids, test equipment, controller I/O, relay or contactor coils, computers, transformers, power supplies, medical equipment, and other control equipment. To be applied properly, supplementary protectors require that some form of upstream, branch circuit protection already be in place in the installation. In basic terms, if there is an upstream overcurrent protective device in place which is of proper rating and type to protect the conductors (and the supplementary protector) feeding the circuit, if the circuit is a type which is appropriate for use of a supplementary protector, and if the fault current rating of the supplementary protector is not exceeded, then a supplementary protector can be used in the installation. The benefits of supplementary protection include precise protection of the load components, a small installed size, re-settability after a fault, tripping selectivity, and fault current limitation. Selectivity is detailed in the examples in Figure 5.

**Figure 5 - Tripping Selectivity**

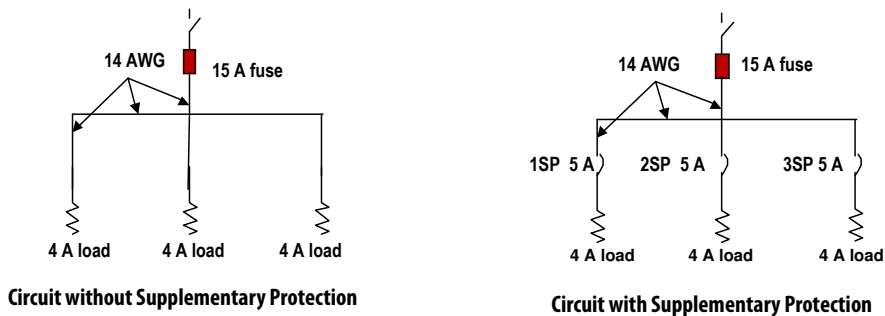

If a fault were to occur in the control circuit that is not using supplementary protectors, the entire circuit would be lost when the fuse blows and power would be removed from all loads. Depending on the application, this could result in a loss of productivity. On the contrary, the same fault in the circuit with supplementary protection would only disable the part of the circuit where the fault occurred. The remaining loads would remain powered, and losses in productivity are minimized.

## Sample Circuit

The following circuit diagram shows several examples of how supplementary protectors can be properly applied. In this diagram, the main circuit breaker provides Short Circuit protection for the 2 AWG wire that is feeding the various circuits. There are two control circuits, each with their own control transformer. Both control transformers are protected with fuses. In circuit 1, the control transformer has fuses on only the primary side which would be sized to protect the primary wiring, the transformer itself, and the secondary side wiring. In circuit 2 the control transformer has both primary side and secondary side fusing. In both cases, the individual control loads are being protected by the supplementary protectors. Circuit 3 is a lighting/heating circuit that is protected by a 15 A fuse, with individual supplementary protectors for each load.

**IMPORTANT** The wire gauge is 14 AWG, with an ampacity of 15, which is protected by the 15 A fuse. The individual loads fed by this conductor can then be protected with supplementary protectors.

**Figure 6 - Circuit Diagram, Supplementary Protector Applications**

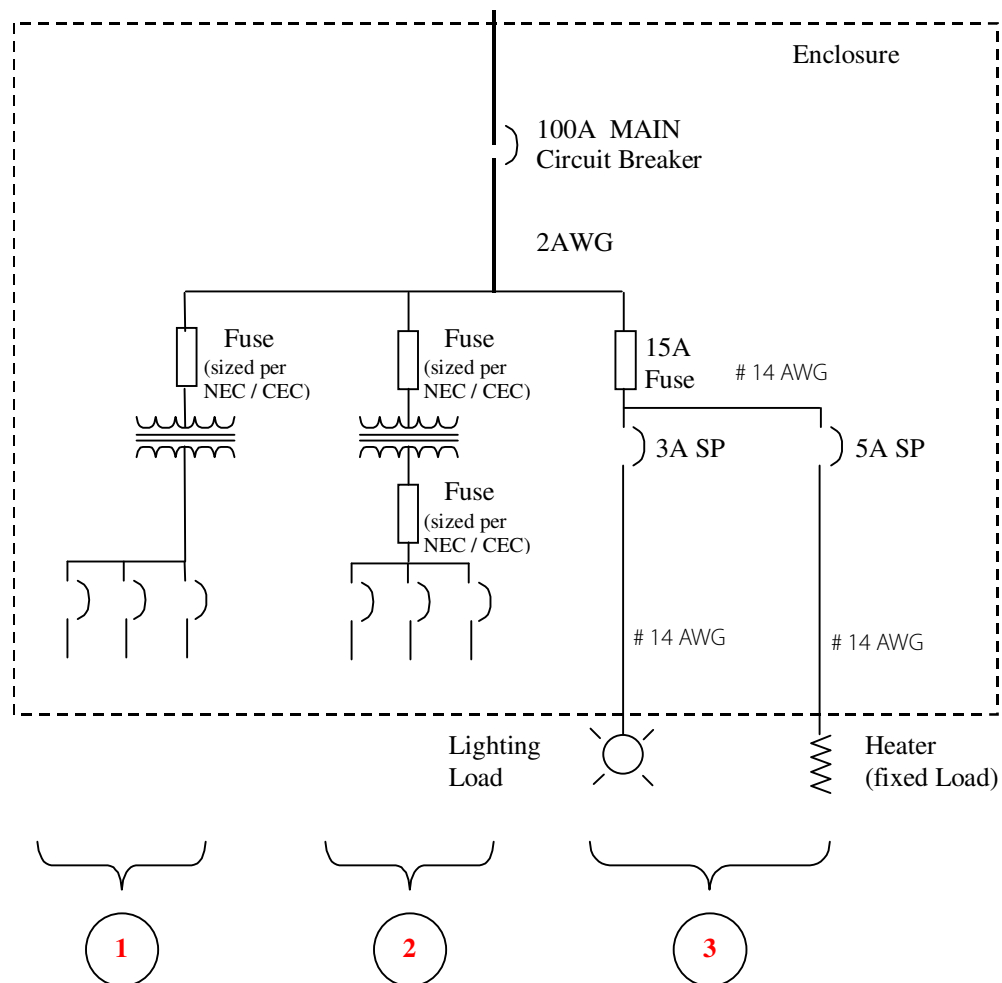

## Typical Load Types

### Resistance Heaters

UL 508A addresses the sizing of overcurrent protection for resistive heater loads.<sup>4</sup> Resistive heaters and other non-inductive loads are termed fixed loads, meaning that they are not subject to increased current levels due to overloads. They are however susceptible to fault current associated with a Short Circuit. Fixed loads can be protected by supplementary protectors where appropriate upstream Short Circuit protection is present. The wire in such installations must be sized for the load current. Addition of supplementary protection between the fuse or circuit breaker and the end load can provide selectivity, resetability, switching capability, and enhanced Short Circuit protection. Shown is an example of such an installation.

**Figure 7 - Fixed Load Example**

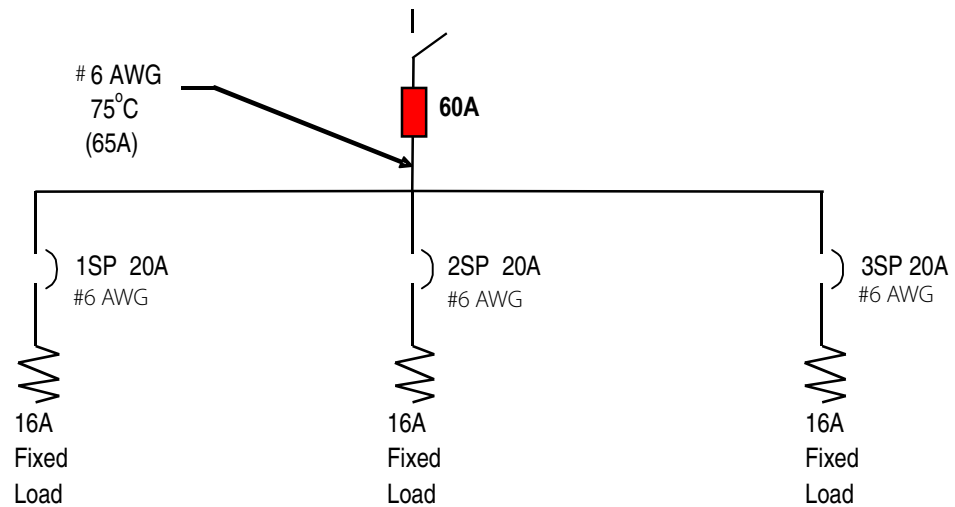

## Receptacles - Control Circuits

Receptacles are generally considered branch circuits and require branch circuit protection such as fuses or a UL 489 circuit breaker. But there is an exception when the receptacle is *within a control circuit* and has a specific intended use. If the control circuit is protected by a branch circuit protective device, UL 508A indicates that a lesser rated overcurrent protective device can be used for protection of the receptacle itself, as long as the ampere rating of the overcurrent device and intended use of the receptacle are marked.<sup>4</sup> Within a control circuit the intended use is limited to devices associated with programming or equipment diagnostics. In these cases a supplementary protector can be used as the overcurrent protective device. The key elements are that the receptacle is within a control circuit, has a specific intended use, and is properly identified as to its intended use.

However, many inspectors have insisted that the receptacle, even located within the control enclosure, is a general-purpose device that can be used not only for the programming equipment but for general-purpose devices such as a drill. They are insisting upon seeing the receptacle protected by a branch circuit breaker or branch circuit protection rated fuses.

Some inspectors and NFPA 79 insist that the receptacle be protected by a GFCI to protect an operator from the danger of a ground fault. UL 508A states that if the enclosure is designed for wet environments (such as type 3 or 4 or similar) the receptacle needs GFCI protection.

**Figure 8 - Receptacle Circuit**

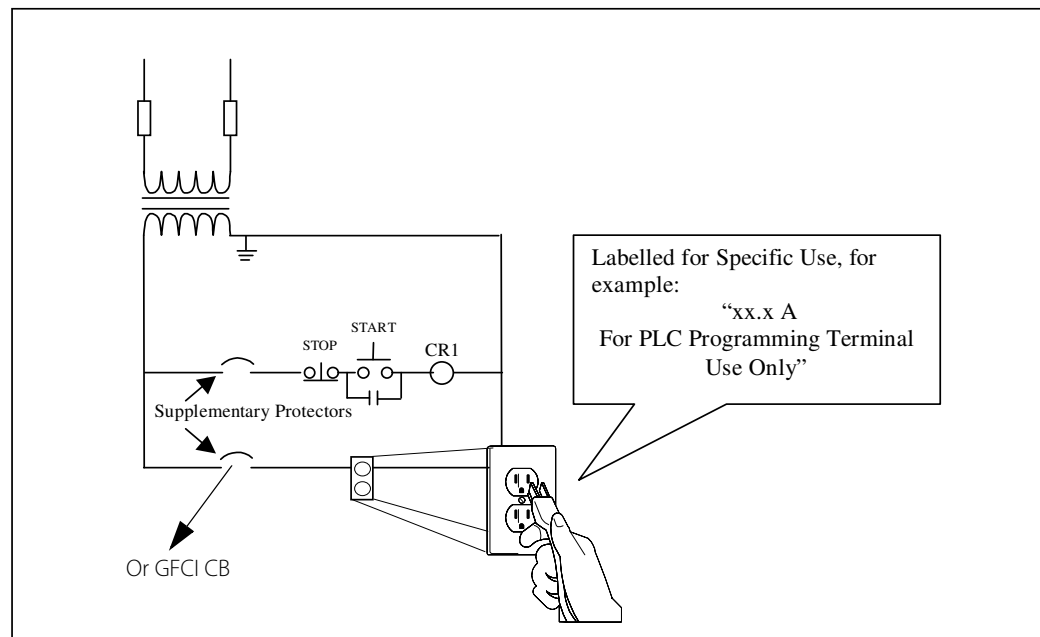

## Control Transformers

### Transformer Primaries

In US markets, Control circuit transformer primaries may be protected with supplementary protectors when there is upstream branch circuit protection available and when it is sized appropriately to protect the conductors feeding the control transformer. For example a 2 kVA transformer, 480V/120V, with 1% impedance has a rated primary current of  $2000/480 = 4.2$  A. Assume that the conductor on the primary side is 14 AWG with an ampacity of 20 A. Since the primary current is 4.2 A, UL 508A dictates that the maximum over-current protective device should be rated 167% of the primary current.<sup>4</sup> In this case it is 7 A. The NEC requires that the 14 AWG wire be protected at 15 A (except for some special conditions identified in ART240 of the code), so there is extra capacity within the conductor that can be taken advantage of with proper circuit design. The NFPA's primary concern, as outlined in the NEC, is not necessarily component protection, but rather conductor protection and reduction of potential fire damage. Using a 15 A fuse or circuit breaker will provide protection for the 14 AWG conductor, but the transformer itself could be damaged in the event of a Short Circuit. Protection at 7 A is still required to reduce the possibility of component damage. In US installations this protection can be provided with a supplementary protector. If we size the protector at 7 A, we take advantage of the conductors capacity and could actually have multiple parallel control circuits (or other small loads) protected with the single 15 A primary fuse as shown below. The supplementary protector used in such an installation must carry the U2 Short Circuit classification (as defined by UL) and be applied within its ratings.

**Figure 9 - Transformer Primaries**

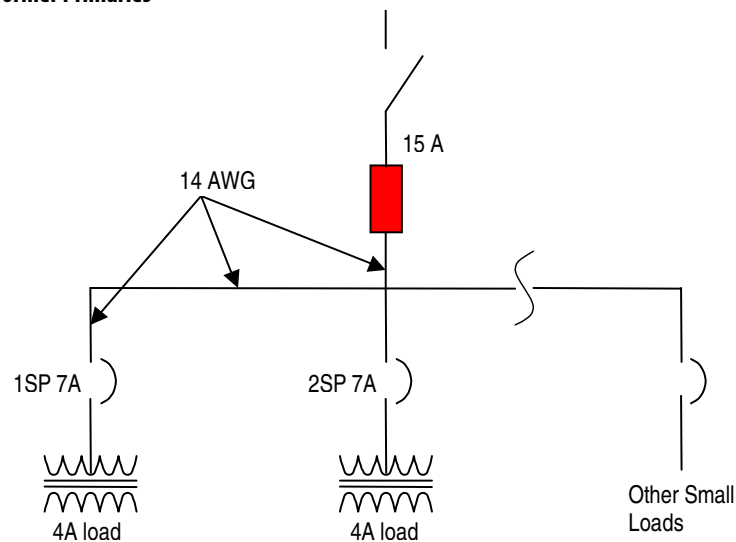

## Transformer Secondaries

Application of supplementary protectors on the secondary side of a control transformer is one of the most common uses of UL 1077 devices in US and Canadian installations. Used in this fashion, the supplementary protector can provide protection to the entire control circuit or several protectors can be used to provide protection to individual control circuit components. The impedance of a transformer effectively limits the fault current that will be seen on the secondary, so supplementary protectors are generally adequate for the levels of energy that could be seen under fault conditions. For example, a 2 kVA transformer, 480/120V, with 1% impedance has a rated primary current of  $2000/480 = 4.2$  A. The secondary current is 16.6 A. The available fault current on the secondary is  $2000 A / (120V \times 0.01) = 1667$  A, which is within the allowable rating of many supplementary protectors. A 5% impedance transformer in the same application would have an AFC of 333 A, which would open up product application to a wider range of supplementary protectors. This example demonstrates that the fault currents that could be seen by the secondary side overcurrent device can vary greatly with component selection. But generally in control circuits, the maximum currents seen during a Short Circuit are at levels suitable for a UL 1077 device to be used.

UL 508A indicates that a control circuit is typically 15...20 A. With a 120V secondary, most applications consider that a 2 kVA transformer is the limit of a control circuit transformer. In UL 508A, Tables 42.1 and 42.2 show sizing of primary winding and primary with secondary overcurrent protection of a control transformer.

**Figure 10 - Transformer Secondaries**

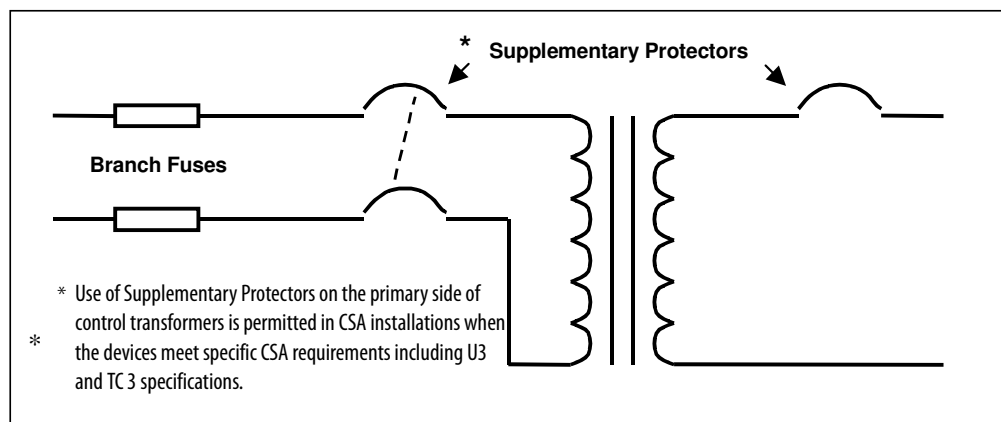

## Power Transformers

In the United States, transformers that are greater than 2 kVA are considered power transformers. UL 508A requires that the primary of a Power Transformer have branch circuit protection devices. If a secondary protection device is used, then that device, too, must be branch circuit rated device.

If a motor is included in the secondary of a transformer, then the transformer is to be treated as a power transformer, no matter what the rating of the transformer. However, the application of an enclosure ventilating fan is considered part of the control circuit and is not treated as a motor for purposes of determining whether a transformer is a control circuit or a power transformer.

In Canada, all transformers are protected with branch circuit protection.

## Motor Loads

Generally, supplementary protectors are not designed or approved for protection of motors in an industrial control environment. When a UL 1077 supplementary protector also holds a motor rated supplementary protector rating, it may be used to provide protection to a motor load. Supplementary protectors that include a Motor Load rating for US applications include an OL1 Overload Rating. This protection is only supplementary and there must still be upstream fusing provided ahead of the supplementary protector. A key point to note is that a motor rated supplementary protector does not automatically carry a motor disconnect rating. (An additional point to note is that a UL 1077 supplementary protector may also carry a classification as an IEC Miniature Circuit Breaker (MCB) (IEC 60 898 or 60 947-2). For IEC installations an MCB may be suitable for Motor Loads.)

Supplementary protectors are not specifically manual motor controllers and should not be used to switch a motor on or off. A UL 508 rated manual motor controller does carry a motor disconnect rating, and while still requiring upstream fusing, can be used for motor control and overload protection, which enables them to be used as a manual motor starter. Some available devices are rated as both a supplementary protector when used in supplementary protection applications and also are rated as manual motor controllers when used in manual motor controller applications.

**IMPORTANT** A Supplementary Protector (UL 1077) may be rated with a UL Recognition (UR) but may not receive a UL Listing (UL), based upon the UL 1077 standard. A Manual Motor Controller may receive a UL Listing under UL 508. Devices that have a dual rating as both a UL 1077 device and a Manual Motor Controller may then have a UL Listing when used as a Manual Motor Controller and a UR recognition when used as a supplementary protector.

Inverse time (thermal-magnetic) circuit breakers, with UL 489 approval, may be used to switch a motor on or off. The UL 489 investigation is sufficient to permit a motor disconnect application. Since the circuit breaker provides branch circuit protection, there is not a requirement of any upstream branch circuit protection. Product sizing of a circuit breaker for a motor load is given by the Nation Electric Code, and UL 508A.

### Sizing of Motor Branch Circuit

- For inverse-time circuit breaker (100 A and less)
- 250% of motor FLA
- If necessary may go to - 400% motor FLA, max
- When selecting the circuit breaker, is it permitted to use the next standard size, but the circuit breaker cannot exceed the maximum noted above.

The degree of overload protection obtained with this application is dependent on the specifics of the circuit breaker as well as the characteristic of the motor. Appropriate wire size needs to be used based upon the size of the circuit breaker determined in above sizing explanation.

**Figure 11 - Motor Branch Circuit**

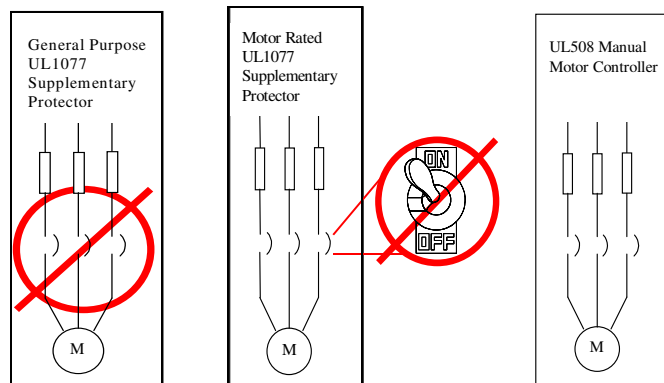

## Summary

Circuit protection is an important part of any electrical installation. The wide variety of products and product ratings can make proper component selection a complex task. Compliance with the applicable local and national codes is necessary to maintain product safety. Understanding the differences between branch circuit protection, supplementary protection, and self-protected products helps to achieve their proper use.

### List of References

- 1) UL Standard for Safety for Molded-Case Circuit Breakers, Molded-Case Switches, and Circuit-Breaker Enclosures, UL 489  
Eleventh Edition, Dated September 1, 2009  
Underwriters Laboratories Inc. (UL)  
333 Pfingsten Road  
Northbrook, IL 60062-2096
  - 2) UL Standard for Safety for Supplementary Protectors for Use in Electrical Equipment, UL 1077  
Sixth Edition, Dated July 14, 2005  
Underwriters Laboratories Inc. (UL)  
333 Pfingsten Road  
Northbrook, IL 60062-2096
  - 3) UL Standard for Safety for Industrial Control Equipment, UL 508  
Seventeenth Edition, Dated January 28, 1999  
Underwriters Laboratories Inc. (UL)  
333 Pfingsten Road  
Northbrook, IL 60062-2096
  - 4) UL Standard for Safety for Industrial Control Panels, UL 508A  
Second Edition, Dated February 26, 2003  
Underwriters Laboratories Inc. (UL)  
333 Pfingsten Road  
Northbrook, IL 60062-2096
  - 5) NFPA 70, National Electric Code (2008 edition)  
Copyright 2007  
National Fire Protection Association, Inc.  
One Batterymarch Park  
Quincy, Massachusetts 02269
  - 6) CAN/CSA 22.2 No. 235-04 (R2009), Supplementary Protectors  
Copyright 2004  
Canadian Standards Association  
5060 Spectrum Way, Suite 100  
Mississauga, Ontario, Canada L4W 5N6
-

Rockwell Automation maintains current product environmental information on its website at <http://www.rockwellautomation.com/rockwellautomation/about-us/sustainability-ethics/product-environmental-compliance.page>.

Allen-Bradley, Rockwell Software, Rockwell Automation, and LISTEN. THINK. SOLVE are trademarks of Rockwell Automation, Inc. Trademarks not belonging to Rockwell Automation are property of their respective companies.

**[www.rockwellautomation.com](http://www.rockwellautomation.com)**

---

**Power, Control and Information Solutions Headquarters**

Americas: Rockwell Automation, 1201 South Second Street, Milwaukee, WI 53204-2496 USA, Tel: (1) 414.382.2000, Fax: (1) 414.382.4444

Europe/Middle East/Africa: Rockwell Automation NV, Pegasus Park, De Kleetlaan 12a, 1831 Diegem, Belgium, Tel: (32) 2 663 0600, Fax: (32) 2 663 0640

Asia Pacific: Rockwell Automation, Level 14, Core F, Cyberport 3, 100 Cyberport Road, Hong Kong, Tel: (852) 2887 4788, Fax: (852) 2508 1846

Publication 1492-WP001D-EN-P - June 2017

Supersedes Publication 1492-WP001C-EN-P - December 2010

Copyright © 2017 Rockwell Automation, Inc. All rights reserved. Printed in the U.S.A.