

# SMC™-3 Specifications

Bulletin Number 150

Topic	Page
Product Overview	2
Standards Compliance and Certifications	2
Features	3
Catalog Number Explanation	4
Wiring Diagrams	6
General Specifications	8
Approximate Dimensions	13

## Additional Resources

These documents contain additional information concerning related products from Rockwell Automation.

Resource	Description
Industrial Automation Wiring and Grounding Guidelines, publication <a href="#">1770-4.1</a>	Provides general guidelines for installing a Rockwell Automation industrial system.
Product Certifications website, <a href="http://www.ab.com">http://www.ab.com</a>	Provides declarations of conformity, certificates, and other certification details.

You can view or download publications at <http://www.rockwellautomation.com/literature/>. To order paper copies of technical documentation, contact your local Allen-Bradley distributor or Rockwell Automation sales representative.





Features	SMC™-3 200...600V 1...480 A
Soft Start	S
Kickstart	S
Current Limit	S
Soft Stop	S
Integrated Bypass Contactor	S
Integrated Motor Overload Protection	S
Inside Delta Connection	S
Standards Compliance: CE Marked per Low Voltage Directive 73/23/EEC, 93/68/EEC CSA Certified (File No. LR 1234) UL Listed (File No. E96956)	S

S = Standard Feature

**Standards Compliance**

UL 508  
CSA C22.2 No.14  
EN/IEC 60947-1  
EN/IEC 60947-4-2

**Certifications**

cULus Listed (Open Type) (File No. E96956, Guides NMFT, NMFT7)  
CSA Certified (File No. LR 1234)  
CE Marked (Open Type) per EMC and Low Voltage Directive  
CCC Certified

**Modes of Operation**

- Soft Start
- Current Limit Start
- Selectable Kickstart
- Soft Stop

**Note:** For detailed information about the different modes of operation, see page 3

## Description of Features

### Electronic Motor Overload Protection

The SMC-3 controller incorporates, as standard, electronic motor overload protection. This motor overload protection is accomplished electronically with the use of current transformers on each of the three phases. The controller's overload protection is programmable, providing the user with flexibility. The overload trip class selection consists of either OFF, 10, 15, or 20. The trip current is easily selected by adjusting the rotary potentiometer to the motor full-load current rating. Trip reset is selectable to either automatic or manual mode.

**Note:** Trip rating is 120% of dial setting.

### Over-temperature

The SMC-3 monitors the SCR temperature by means of internal thermistors. When the power poles maximum rated temperature is reached, the microcomputer switches off the SMC, a TEMP fault is indicated via LED, and the 97/98 fault contact closes.

### Phase Reversal Protection

When enabled via a DIP switch, 3-phase input power will be verified before starting. If input power phasing is detected to be incorrect, the start will be aborted and a fault indicated.

### Phase Loss/Open Load

The unit will not attempt a start if there is a single-phase condition on the line. This protects from motor burnout during single-phase starting.

### Phase Imbalance

The unit monitors for imbalance between phase currents. To prevent motor damage, the unit will trip if the difference between the minimum phase current and the maximum phase current exceeds 65% for 3 s, and a fault will be indicated.

### Shorted SCR

Prior to every start and during starting, the unit will check all SCRs for shorts and unit load connections to the motor. If there is a shorted SCR in the SMC-3 and/or open load, the start will be aborted and a shorted SCR or open load fault will be indicated. This prevents damage from phase imbalance.

### Push to Test

The unit with control wiring can be tested for fault conditions by using the Push to Test function. Hold down the Reset button for 7 s to activate the fault Aux (97, 98) and shut down the SMC-3. To clear, either push the Reset button or cycle control power to the device.

### LED Description (Number of Flashes)

1. Overload
2. Overtemperature
3. Phase Reversal
4. Phase Loss/Open Load
5. Phase Imbalance
6. Shorted SCR
7. Test

Cat. No. Explanation  
Open and Non-Combination

150
–
C
30
F
B
D
–
8L

*a*
*b*
*c*
*d*
*e*
*f*
*g*

*a*

Bulletin Number	
Code	Description
150	Solid-State Controller

*b*

Controller Type	
Code	Description
C	SMC-3

*c*

Ampere Ratings	
Code	Description
3	3 A
9	9 A
16	16 A
19	19 A
25	25 A
30	30 A
37	37 A
43	43 A
60	60 A
85	85 A
108	108 A
135	135 A
201	201 A
251	251 A
317	317 A
361	361 A
480	480 A

*d*

Enclosure Type	
Code	Description
N	Open
F	NEMA 4/12 (IP65)

*e*

Input Line Voltage Open Type	
Code	Description
B	200...460V AC, 3-Phase, 50/60 Hz
C	200...600V AC, 3-Phase, 50/60 Hz
Non-Combination Enclosed Only	
H	200...208V AC, 3-Phase, 50/60 Hz
A	230V AC, 3-Phase, 50/60 Hz
B	400...460V AC, 3-Phase, 50/60 Hz
C	500...575V AC, 3-Phase, 50/60 Hz

*f*

Control Voltage	
Code	Description
D	100...240V AC
R	24V AC/DC (Open Type only)

*g*

Options (see page 42 for a full listing)	
Code	Description
8L	Line-Mounted Protective Module
8M	Load-Mounted Protective Module
8B	Line- and Load-Mounted Protective Modules
Load-side MOVs are not available with Pump and Braking options, or when used with inside-the-delta connections.	

Combination

152H – C
30
F
BD
43 – 8L

*a*
*b*
*c*
*d*
*e*
*f*
*g*

*a*

Bulletin Number	
Code	Description
152H‡	Solid-State Controller with Fusible Disconnect
153H‡	Solid-State Controller with Circuit Breaker

*b*

Controller Type	
Code	Description
C	SMC-3

*c*

Ampere Ratings	
Code	Description
3	3 A
9	9 A
16	16 A
19	19 A
25‡	25 A
30	30 A
37	37 A
43‡	43 A
60	60 A
85‡	85 A
108‡	108 A
135‡	135 A
201‡	201 A
251	251 A
317‡	317 A
361‡	361 A
480‡	480 A

*d*

Enclosure Type	
Code	Description
F	NEMA Type 4/12 (IP65)
X‡	NEMA Type 3R (IP44)

*e*

Input Line Voltage Open Type	
Code	Description
HD	200...208V AC, 3-Phase, 50/60 Hz
AD	230V AC, 3-Phase, 50/60 Hz
BD‡	400...460V AC, 3-Phase, 50/60 Hz
CD	500...575V AC, 3-Phase, 50/60 Hz

*f*

Horsepower									
Cat. No.	Hp Rating	Cat. No.	Hp Rating	Cat. No.	Hp Rating	Cat. No.	Hp Rating	Cat. No.	Hp Rating
33	0.5	39	5	46‡	40	52‡	150	60	450
34	0.75	40	7.5	47‡	50	54	200	61	500
35	1	41‡	10	48‡	60	56‡	250	62	600
36	1.5	42‡	15	49‡	75	57‡	300	63	700
37	2	43‡	20	50‡	100	58‡	350	65	800
38	3	44‡	25	51‡	125	59‡	400	67	1000
—	—	45‡	30	—	—	—	—	—	—

*g*

Options (see page 42 for a full listing)	
Code	Description
8L	Line-Mounted Protective Module
8M	Load-Mounted Protective Module
8B	Line- and Load-Mounted Protective Modules

Load-side MOVs are not available with Pump and Braking options, or when used with inside-the-delta connections.

‡ Pump Panel only available for highlighted configuration. Start push button, external reset, HOA, and transformer are included as standard.

Two-Wire Configuration

IEC

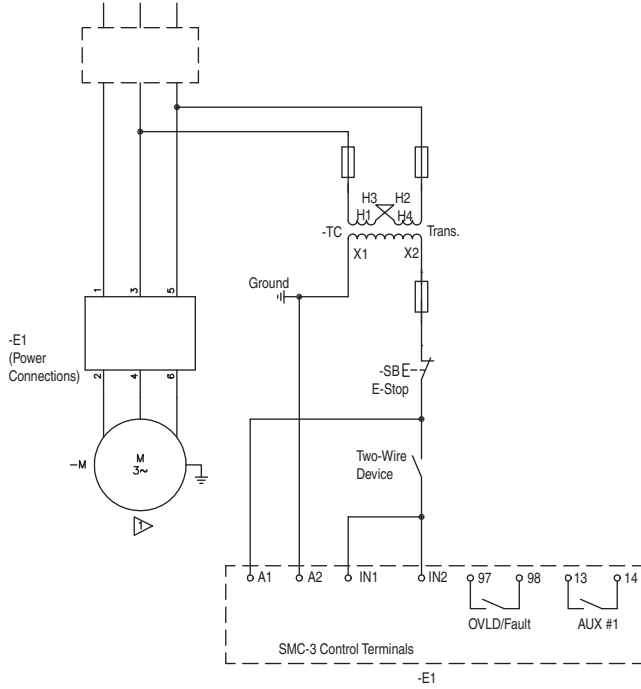

NEMA

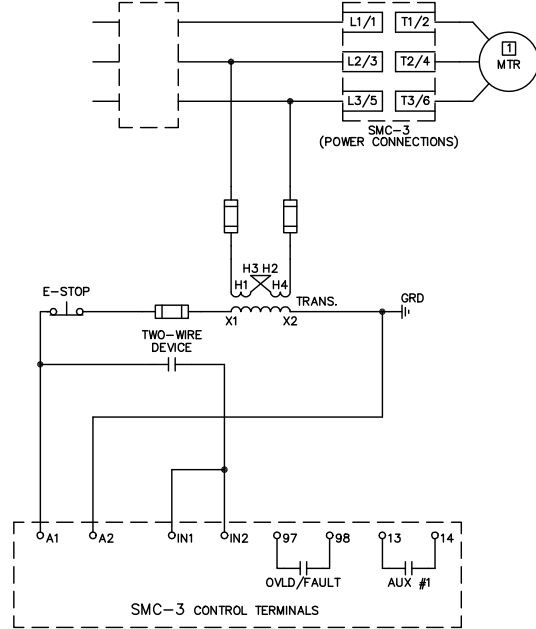

Three-Wire Configuration

IEC

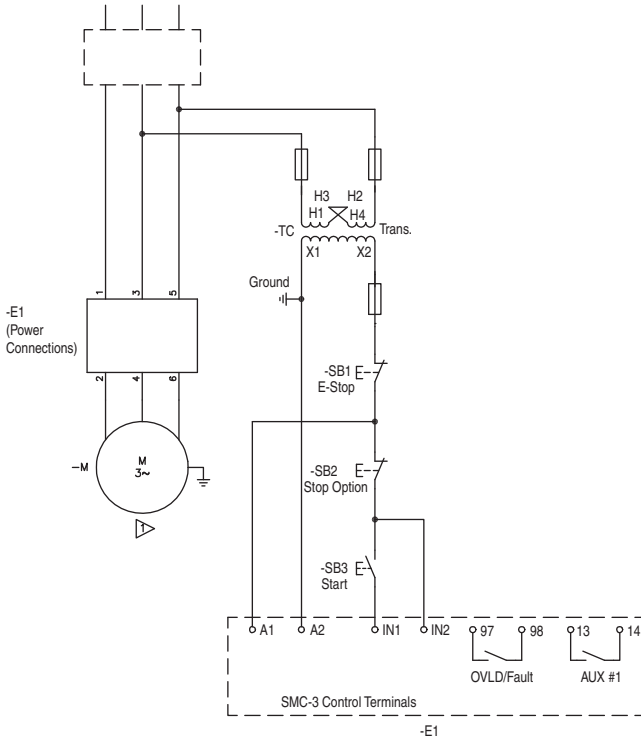

NEMA

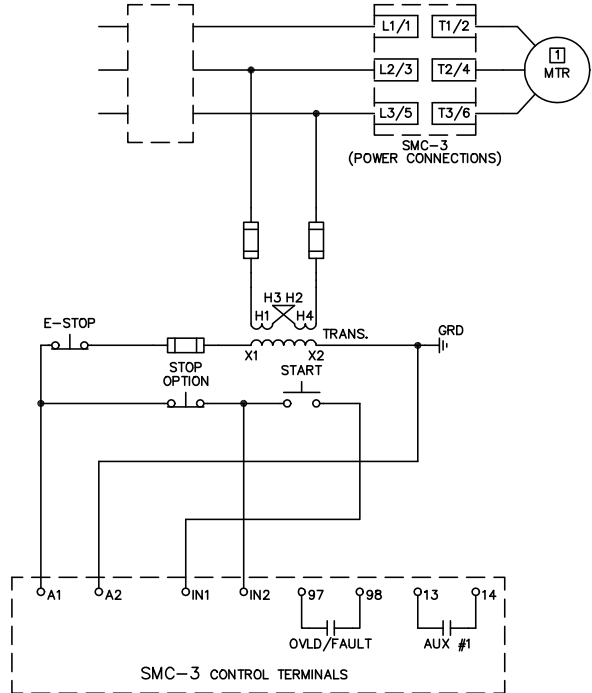

Isolation Contactor Configuration

IEC

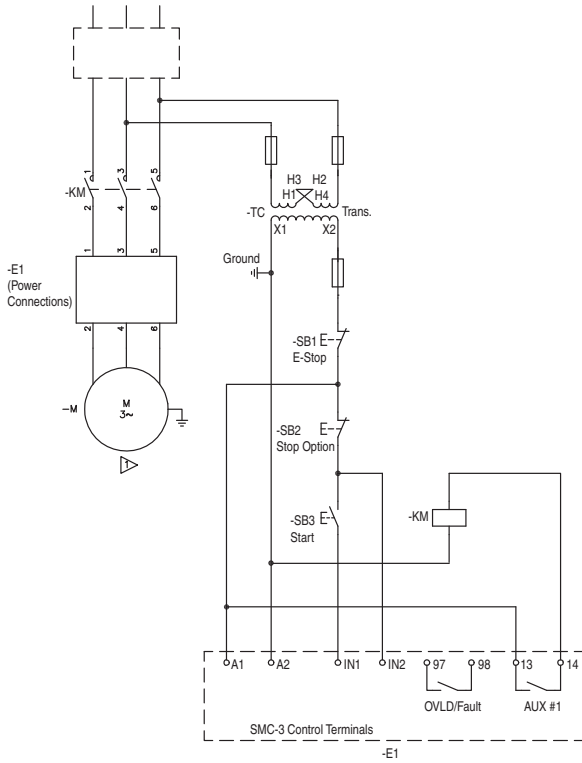

NEMA

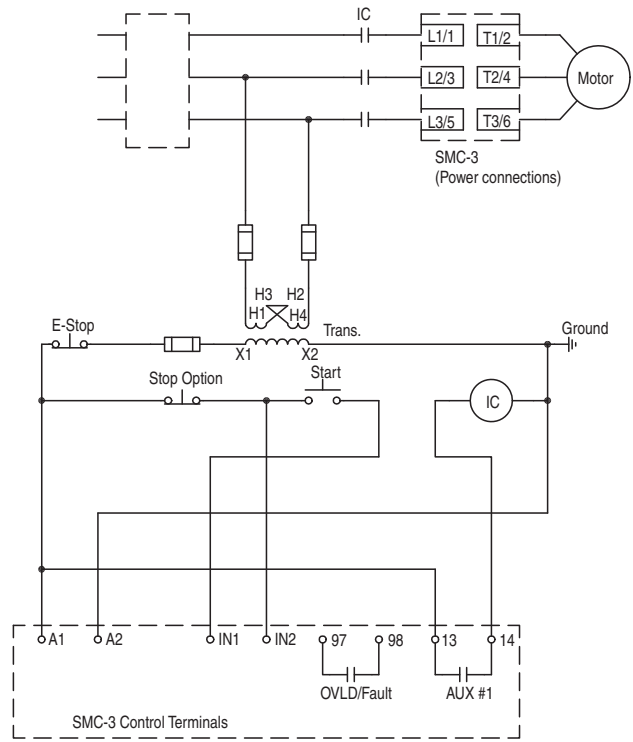

Reversing Configuration

Note: Minimum Off time equals 1.0 s.

IEC

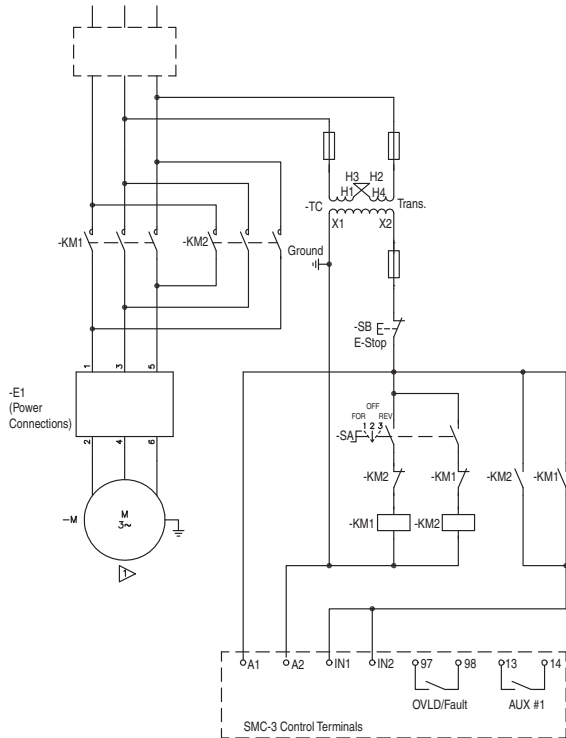

NEMA

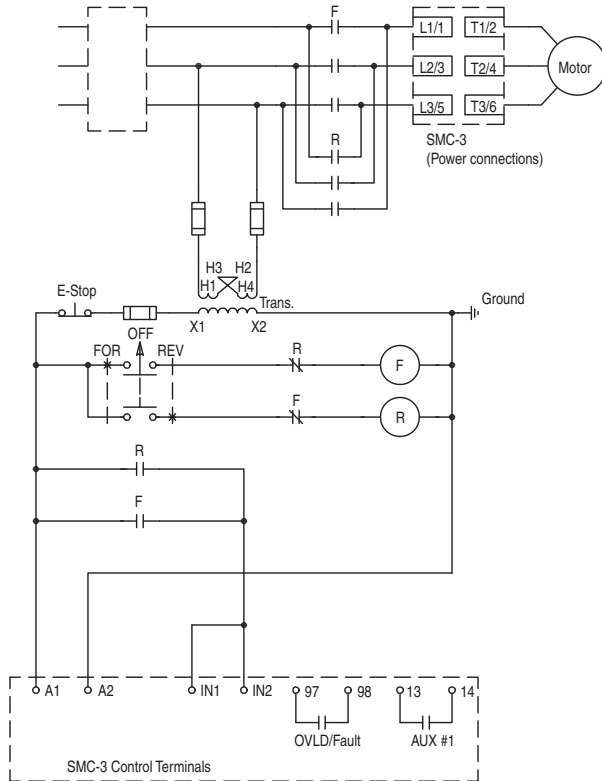

Standard Features								
Selectable Start Times	2, 5, 10, 15, 20, 25, or 30 s							
Selectable Initial Torque	0%, 25%, 35%, and 65% of locked rotor torque							
Selectable Current Limit	150%, 250%, 350%, and 450% of full load current							
Selectable Kick Start — 450% FLA	0, 0.5, 1.0, or 1.5 s							
Selectable Soft Stop	Off, 100%, 200%, or 300% of the start time setting when wired							
Electrical Ratings								
Power Circuit	UL/CSA/NEMA			IEC				
	Rated Operation Voltage	200...480V AC 200...600V AC			200...480V~ — 400V~ 500V~ — 500V~			
	Rated Insulation Voltage	600V AC			500V~			
	Dielectric Withstand	2200V AC			2500V~			
	Repetitive Peak	200...480V AC: 1400V 200...600V AC: 1600V			200...480V~: 1400V 500V~: 1600V			
	Operating Frequency	50/60 Hz			50/60 Hz			
	Utilization Category	1...37 A	—			AC-53b: 3.5-15:3585		
		43...60 A	—			AC-53b: 4.5-30:1770		
		85 A	—			AC-53b: 4.5-30:3570		
		108 A	—			AC-53b: 4.5-30:1770		
		135 A	—			AC-53b: 3.5-30: 1770		
		201...251 A	—			AC-53b: 3.5-30: 1770		
		317...480 A	—			AC-53b: 3.5-30: 1770		
	Number of Poles	Equipment designed for 3-phase only						
Rated Impulse Voltage	6 kV							
DV/DT Protection	1000V/μs							
Overvoltage Category	III							
Short Circuit Protection	SCPD Performance		Type 1 ⚡Δ					
			Non-Time Delay		Thermal Magnetic Circuit Breaker		High Capacity Time Delay Class CC/JL	
	SCPD List§		Max. Standard Available Fault	Max. Standard Fuse [A]‡	Max. Standard Available Fault	Max. Circuit Breaker [A]	Max. Standard Available Fault	Max. Fuse [A]
	Line Device Operational Current Rating [A]	3	5 kA	12	5 kA	15	70 kA	6
		9	5 kA	30	5 kA	30	70 kA	15
		16	5 kA	60	5 kA	60	70 kA	30
		19	5 kA	70	5 kA	70	70 kA	40
		25	5 kA	100	5 kA	100	70 kA	50
		30	10 kA	110	10 kA	110	70 kA	60
		37	10 kA	125	10 kA	125	70 kA	60
		43	10 kA	150	10 kA	150	70 kA	90
		60	10 kA	225	10 kA	225	70 kA	125
		85	10 kA	300	10 kA	300	70 kA	175
		108	10 kA	400	10 kA	300	70 kA	200
135		10 kA	500	10 kA	400	70 kA	250	
201		18 kA	600	18 kA	600	70 kA	350	
251	18 kA	700	18 kA	700	70 kA	400		
317	30 kA	800	30 kA	800	69 kA	500		
361	30 kA	1000	30 kA	1000	69 kA	600		
480	42 kA	1200	42 kA	1200	69 kA	800		
Delta Device Operational Current Rating [A]	5.1	5 kA	15	5 kA	15	70 kA	10	
	16	5 kA	60	5 kA	60	70 kA	30	
	27.6	5 kA	70	5 kA	70	70 kA	60	
	32.8	5 kA	125	5 kA	125	70 kA	70	
	43	5 kA	150	5 kA	150	70 kA	90	
	52	10 kA	200	10 kA	200	70 kA	100	
	64	10 kA	250	10 kA	250	70 kA	100	
	74	10 kA	250	10 kA	250	70 kA	150	
	104	10 kA	400	10 kA	300	70 kA	225	
	147	10 kA	400	10 kA	400	70 kA	300	
	187	10 kA	600	10 kA	500	70 kA	400	
	234	10 kA	700	10 kA	700	70 kA	400	
	348	18 kA	1000	18 kA	1000	70 kA	600	
435	18 kA	1200	18 kA	1200	69 kA	800		
549	30 kA	1600	30 kA	1600	69 kA	1000		
625	30 kA	1600	30 kA	1600	69 kA	1200		
831	42 kA	1600	30 kA	1600	69 kA	1600		
831	42 kA	1600	42 kA	1200	69 kA	1600		

‡ Non-time delay fuses (K5).

§ Consult local codes for proper sizing of short-circuit protection.

⚡ Type 1 performance/protection indicates that, under a short-circuit condition, the fused or circuit breaker-protected starter shall cause no danger to persons or installation but may not be suitable for further service without repair or replacement.



Electrical Ratings				
		UL/CSA/NEMA	IEC	
Control Circuit	Rated Operational Voltage (+10%, -15%)	100...240V AC, 24V AC/DC		
	Rated Insulation Voltage	250V		
	Rated Impulse Voltage	2.5 kV		
	Dielectric Withstand	1500V AC		
	Overvoltage Category	II		
	Operating Frequency	50/60 Hz		
	Input onstate voltage minimum, during start (IN1, IN2)	85V AC, 19.2V DC / 19.2V AC		
	Input onstate current (IN1, IN2)	9.8 mA @120V AC/19.6 mA @ 240V AC, 7.3 mA @ 24V AC/DC		
	Input offstate voltage maximum (IN1, IN2)	40V AC, 17V DC / 12V AC		
	Input offstate current @ input offstate voltage (IN1, IN2)	<10 mA, <12 mA		
	Control Power with Fan, during start	3...37 A	215 mA @ 120V AC / 180 mA @ 240V AC, 800 mA @ 24V DC / 660 mA @ 24V AC	
		43...85 A	200 mA @ 120V AC / 100 mA @ 240V AC, 700 mA @ 24V AC/DC	
			<b>Fan Power</b>	<b>Control Power</b>
		108...135 A	20VA	200 mA @ 120V AC / 120 mA @ 240V AC, 600 mA @ 24V AC/DC
201...251 A		40VA		
317...480 A	60VA			
Control Power without Fan, during start	3...37 A	205 mA @ 120V AC / 145 mA @ 240V AC, 705 mA @ 24V DC / 580 mA @ 24V AC		
Steady State Heat Dissipation and Overload Current Range	Controller Rating [A]	Steady State Heat Dissipation [W]	Overload Current Range [A]	
	3	11	1...3	
	9	12	3...9	
	16	14	5.3...16	
	19	15	6.3...19	
	25	17	9.2...27.7	
	30	19	10...30	
	37	24	12.3...37	
	43	34	14.3...43	
	60	50	20...60	
	85	82	28.3...85	
	108	62	27...108	
	135	75	34...135	
	201	129	67...201	
	251	147	84...251	
317	174	106...317		
361	194	120...361		
480	239	160...480		

Auxiliary Contacts			
		UL/CSA/NEMA	IEC
Rated Operational Voltage		250V AC/30V DC	250V~/30V DC
Rated Insulation Voltage		250V	250V~
Rated Impulse Voltage		2.5 kV	4 kV
Dielectric Withstand		1500V AC	2000V~
Overvoltage Category		II	III★
Operating Frequency		50/60 Hz	50/60 Hz
Utilization Category		D300/D300	AC-15/DC
TB-97, -98 (OVLD/Fault)	Type of Control Circuit	Electromagnetic relay	
	Number of Contacts	1	
	Type of Contacts	Normally Open (N.O.)	
	Type of Current	AC/DC	
	Rated Operational Current (max.)	0.6 A @ 120V~ and 0.3 A @ 240V~	
	Conventional Thermal Current $I_{th}$	1 A	
	Make/Break VA	432/72	
TB-13, -14 Aux 1 (Normal/Up-to-Speed)	Type of Control Circuit	Electromagnetic relay	
	Number of Contacts	1	
	Type of Contacts	Normally Open (N.O.)	
	Type of Current	AC/DC	
	Rated Operational Current (max.)	0.6 A @ 120V~ and 0.3 A @ 240V~	
	Conventional Thermal Current $I_{th}$	1 A	
	Make/Break VA	432/72	

★ Overvoltage category II, when either control or auxiliary circuit is wired to a SELV or PELV circuit.

Electrical Ratings			
Side-Mount Auxiliary Contacts			
		UL/CSA/NEMA	IEC
Rated Operational Voltage		250V AC/30V DC	250V AC/30V DC
Rated Insulation Voltage		250V	250V AC
Rated Impulse Voltage		2.5 kV	4 kV
Dielectric Withstand		1500V AC	2000V AC
Overvoltage Category		II	III★
Operating Frequency		50/60 Hz	50/60 Hz
TB-23, -24 (Normal/Up-to-Speed) TB-33, -34 (Normal/Up-to-Speed)	Utilization Category	C300/R150	AC-15/DC-13
	Type of Control Circuit	Electromagnetic relay	
	Number of Contacts	1	
	Type of Contacts	Normally Open (N.O.)	
	Type of Current	AC/DC	
	Rated Operational Current (max.)	1.5 A @ 120V AC, 0.75A @ 240V AC, 1.17 A @ 24V DC	
	Conventional Thermal Current $I_{th}$	2.5 A	
TB-11, -12 (Normal/Up-to-Speed)	Make/Break VA	1800/180V AC, 28V DC (resistive)	
	Type of Control Circuit	B300/R300	AC-15/DC-13
	Type of Control Circuit	Electromagnetic relay	
	Number of Contacts	1	
	Type of Contacts	Normally Closed (N.C.)	
	Type of Current	AC/DC	
	Rated Operational Current (max.)	3 A @ 120V AC, 1.5A @ 240V AC, 1.17 A @ 24V DC	
Conventional Thermal Current $I_{th}$	5 A		
Make/Break VA	3600/360VA, 28VA (DC resistive)		

★ Overvoltage category II, when either control or auxiliary circuit is wired to a SELV or PELV circuit.

Environmental	
Operating Temperature Range	-5...+50 °C (23...122 °F) (open) -5...+40 °C (23...104 °F) (enclosed)
Storage and Transportation Temperature Range	-25...+85 °C (-13...+185 °F)
Altitude	2000 m (6560 ft)
Humidity	5...95% (non-condensing)
Pollution Degree	2
Type of Protection	IP2X

Mechanical Ratings			
Resistance to Vibration	Operational	1.0 G Peak, 0.15 mm (0.006 in.) displacement	
	Non-Operational	2.5 G Peak, 0.38 mm (0.015 in.) displacement	
Resistance to Shock	Operational	15 G	
	Non-Operational	30 G	
Line Power Terminals	Cable Size Tightening Torque	3...37 A	2.5...25 mm <sup>2</sup> (14...4 AWG) 2.3...2.8 N•m (20...25 in•lbs)
		43...85 A	2.5...95 mm <sup>2</sup> (14...3/0 AWG) 11.3...12.4 N•m (100...110 in•lbs)
		108...135 A	23 N•m (200 in•lbs)
		201...251 A	Two M10 x 1.5 diameter holes per power pole
		317...480 A	Two M12 x 1.75 diameter holes per power pole
Load Power Terminals	Cable Size Tightening Torque	3...37 A	2.5...16 mm <sup>2</sup> (14...6 AWG) 2.3...2.5 N•m (20...22.5 in•lbs)
		43...85 A	2.5...50 mm <sup>2</sup> (14...1 AWG) 11.3...12.4 N•m (100...110 in•lbs)
		108...135 A	23 N•m (200 in•lbs)
		201...251 A	Two M10 x 1.5 diameter holes per power pole
		317...480 A	Two M12 x 1.75 diameter holes per power pole
Control Terminals	Cable Size Tightening Torque	All	0.2...2.5 mm <sup>2</sup> (24...14 AWG) 0.5...0.9 N•m (4.4...8.0 in•lbs)

Other			
		UL/CSA/NEMA	IEC
EMC Emission Levels	Conducted Radio Frequency Emissions	—	Class A
	Radiated Emissions	—	Class A
EMC Immunity Levels	Electrostatic Discharge	4 kV Contact and 8 kV Air Discharge	8 kV Air Discharge
	Radio Frequency Electromagnetic Field	—	Per EN/IEC 60947-4-2
	Fast Transient	—	Per EN/IEC 60947-4-2
	Surge Transient	—	Per EN/IEC 60947-4-2

SMC-3 Overload Trip Curves

Trip Class 10

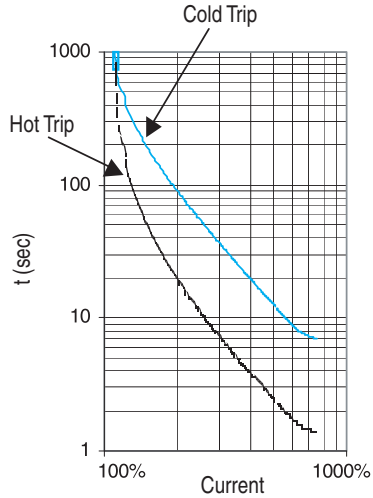

Trip Class 15

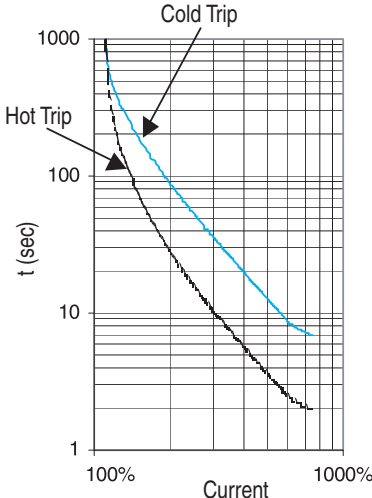

Trip Class 20

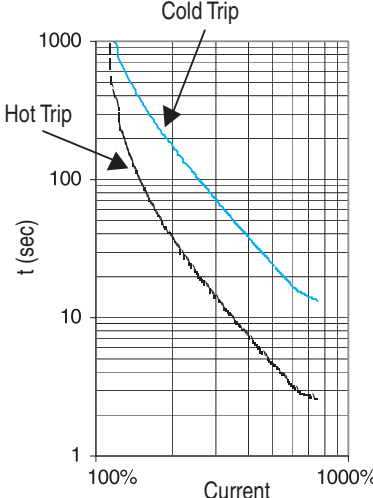

Starts per Hour Curves

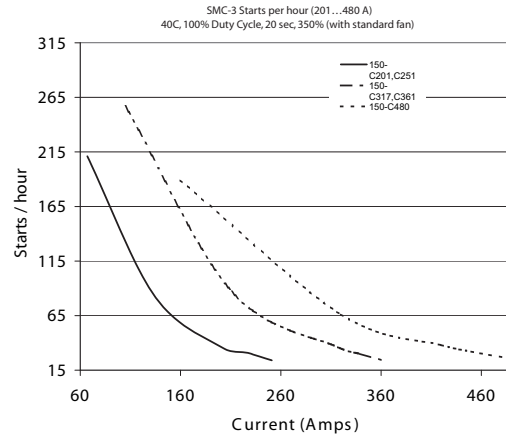
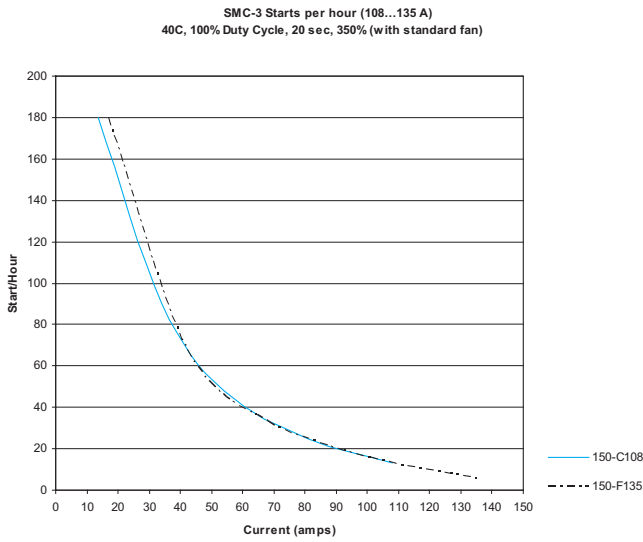
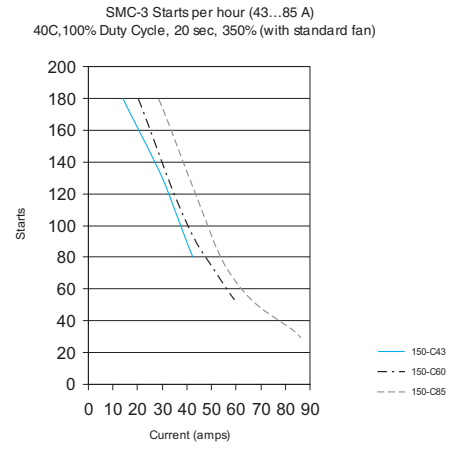
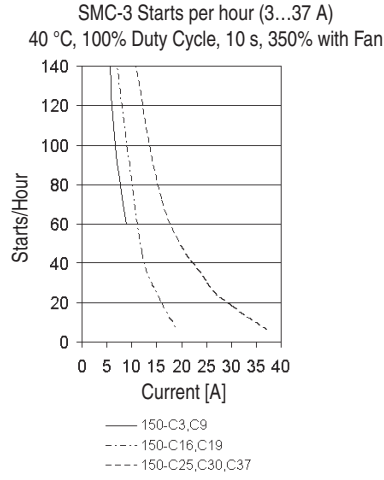
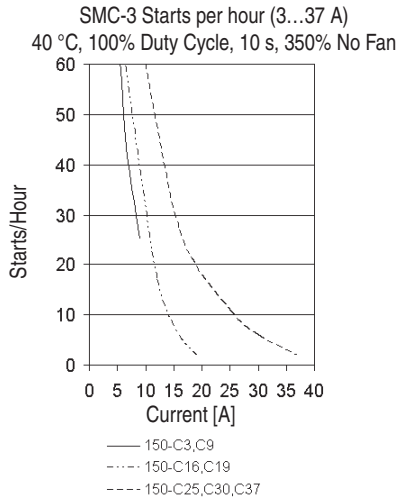

**Approximate Dimensions**

Dimensions in millimeters (inches). Dimensions are not intended to be used for manufacturing purposes. All dimensions are subject to change.

**Open Type**

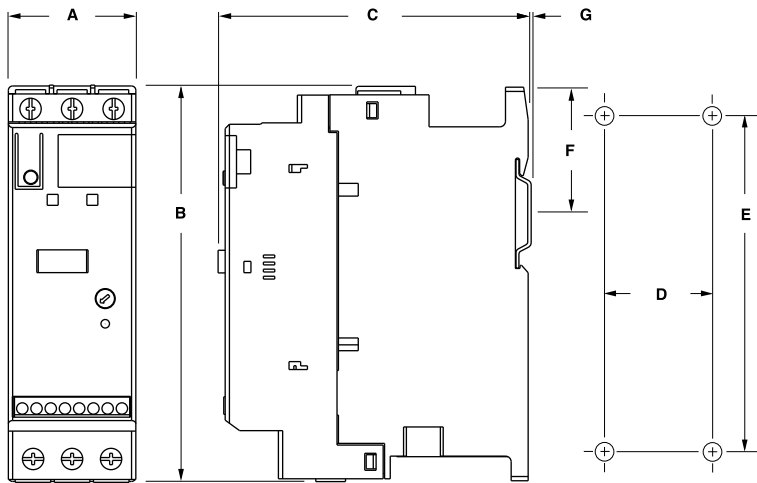

Controller Rating [A]	A	B	C	D	E	F	G	Mounting Hole Size	Weight kg (lbs)
1...37	44.8 (1-49/64)	139.7 (5-1/2)	100 (4-21/64)	35 (1-3/8)	132 (5-13/64)	46.4 (1.81)	2 (1/16)	4.6 (0.18)	0.86 (1.9)
43...85	72 (2.83)	206 (8.11)	130 (5.12)	55 (2.17)	198 (7.8)	102 (4.02)	2 (1/16)	5.3 (0.21)	2.25 (5.0)
108...135	196.4 (7.74)	443.7 (17.47)	205.2 (8.08)	166.6 (6.56)	367 (14.45)	—	—	7.5 (0.295)	15 (33)
201...251	225 (8.86)	560 (22.05)	265.3 (10.45)	150 (5.91)	504.1 (19.85)	—	—	11.5 (0.45)	30.4 (67)
317...480	290 (11.42)	600 (23.62)	298 (11.73)	200 (7.87)	539.2 (21.23)	—	—	11.5 (0.45)	45.8 (101)

**Minimum Enclosure Size**

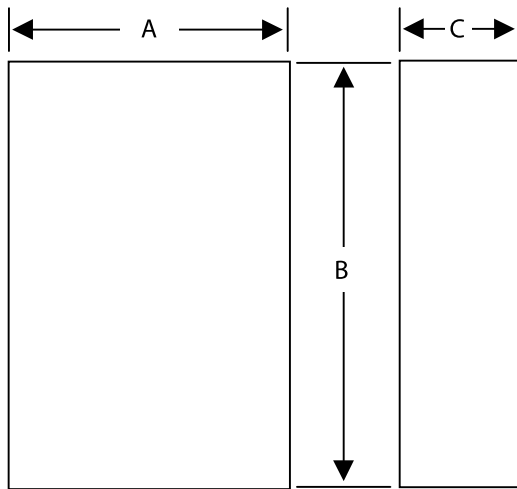

Controller Rating [A]	B Height	A Width	C Depth	Fan Requirements
1...37 A	305 (12)	224 (9)	152 (6)	none
43...85 A	406 (16)	305 (12)	203 (8)	none
108...135 A	762 (30)	610 (24)	305 (12)	none
201...251 A	965 (38)	762 (30)	356 (14)	none
317...480 A	1295 (51)	914 (36)	356 (14)	none

**Enclosed Type Line-Connected Controllers**

Dimensions in millimeters (inches). Dimensions are not intended to be used for manufacturing purposes. All dimensions are subject to change.

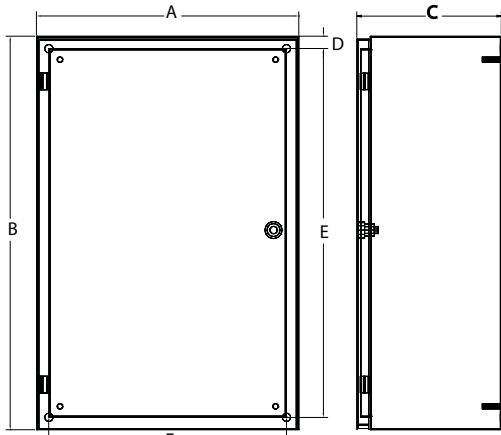

Figure 1 — Wall-Mount

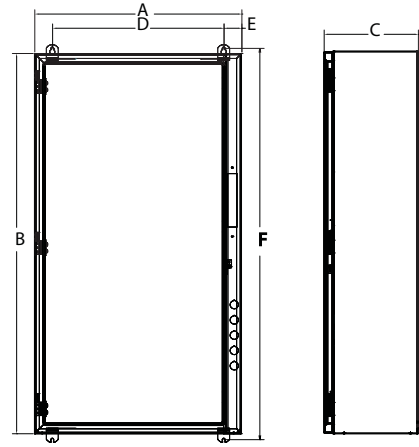

Figure 2 — Wall-Mount

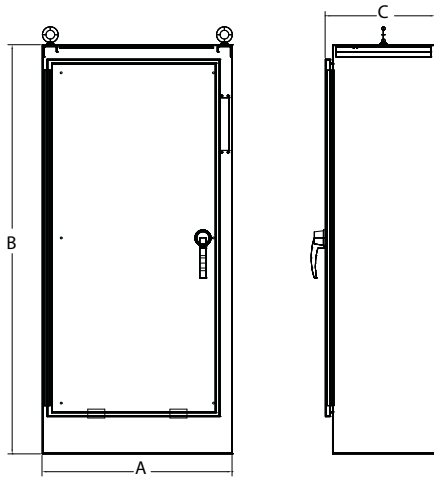

Figure 3 — Floor-Mount

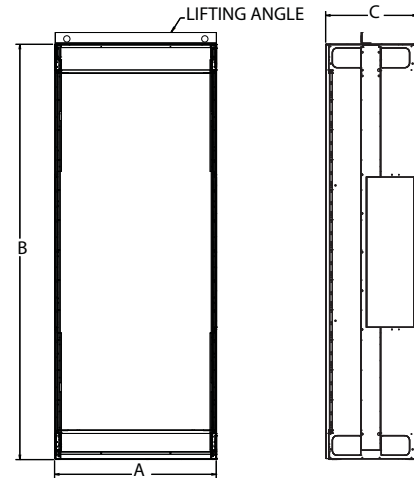

Figure 4 — Floor-Mount

Controller Rating [A]	Bulletin	With Option	Dimension Figure No.	Dimensions in inches (mm)					
				A (Width)	B (Height)	C (Depth)	D (Mtg. Dim.)	E (Mtg. Dim.)	F (Mtg. Dim.)
<b>SMC-3 Non-Combination Controller</b>									
3...37	150	—	1	8 (203)	12 (305)	6 (152)	2.44 (62)	10.43 (265)	3.0 (76)
		6P		12 (305)	12 (305)	6 (152)	2.41 (61)	10.43 (265)	7.0 (178)
43...85	150	—	1	8 (203)	14 (356)	8 (203)	2.44 (62)	12.40 (315)	3.0 (76)
		6P		16 (406)	14 (356)	8 (203)	4.38 (111)	12.40 (315)	7.0 (178)
108...135	150	Any	1	24 (610)	30 (762)	12 (305)	0.75 (19)	28.5 (724)	22.5 (572)
201...251	150	—	1	30 (762)	38 (965)	14 (356)	0.75 (19)	36.5 (927)	28.5 (724)
	150, 150B	BP,NB,NI,6P		36 (914)	51 (1295)	14 (356)	0.75 (19)	49.5 (1257)	34.5 (876)
317...361	150	Any	1	36 (914)	51 (1295)	14 (356)	0.75 (19)	49.5 (1257)	34.5 (876)
		—		36 (914)	51 (1295)	14 (356)	0.75 (19)	49.5 (1257)	34.5 (876)
	150B	NI, 6P		36 (914)	51 (1295)	14 (356)	0.75 (19)	49.5 (1257)	34.5 (876)
		BP,NI, 6P		36 (914)	60 (1524)	14 (356)	0.75 (19)	58.5 (1486)	34.5 (876)
480	150	—	1	36 (914)	51 (1295)	14 (356)	0.75 (19)	49.5 (1257)	34.5 (876)
	150, 150B	BP,NB,NI,6P		36 (914)	60 (1524)	14 (356)	0.75 (19)	58.5 (1486)	34.5 (876)

Controller Rating [A]	Bulletin	With Option	Dimension Figure No.	Dimensions in inches (mm)					
				A (Width)	B (Height)	C (Depth)	D (Mtg. Dim.)	E (Mtg. Dim.)	F (Mtg. Dim.)
<b>SMC-3 Combination Controller</b>									
3...37	152H,153H	Any	1	16 (406)	14 (356)	8 (203)	4.38 (111)	12.40 (315)	7.0 (178)
43	152H	Any	1	16 (406)	14 (356)	8 (203)	4.38 (111)	12.40 (315)	7.0 (178)
	153H	Any	1	16 (406)	24 (610)	10 (254)	0.75 (19)	22.5 (572)	14.5 (368)
60	152H, 153H	Any	1	16 (406)	24 (610)	9 (229)	0.75 (19)	22.5 (572)	14.5 (368)
	152H	Any	1	24 (610)	30 (762)	12 (305)	0.75 (19)	28.5 (724)	22.5 (572)
85	152H	Any	1★	16 (406)	24 (610)	9 (229)	0.75 (19)	22.5 (572)	14.5 (368)
		Any	1‡	24 (610)	30 (762)	12 (305)	0.75 (19)	28.5 (724)	22.5 (572)
	153H	Any	1	16 (406)	24 (610)	9 (229)	0.75 (19)	22.5 (572)	14.5 (368)
108	152H,153H	Any	1	30 (762)	38 (965)	14 (356)	0.75 (19)	36.5 (927)	28.5 (724)
135	152H,153H	Any	1	30 (762)	38 (965)	14 (356)	0.75 (19)	36.5 (927)	28.5 (724)
201	152H,153H	—	1	30 (762)	38 (965)	14 (356)	0.75 (19)	36.5 (927)	28.5 (724)
	152H,152B,153H,153B	Any	1	36 (914)	51 (1295)	14 (356)	0.75 (19)	49.5 (1257)	34.5 (876)
251	152H,153H	—	1	30 (762)	38 (965)	14 (356)	0.75 (19)	36.5 (927)	28.5 (724)
	152H,152B,153H,153B	Any	1	36 (914)	51 (1295)	14 (356)	0.75 (19)	49.5 (1257)	34.5 (876)
317	153H	—	1	36 (914)	51 (1295)	14 (356)	0.75 (19)	49.5 (1257)	34.5 (876)
		BP,NB	1	36 (914)	60 (1524)	14 (356)	0.75 (19)	58.5 (1486)	34.5 (876)
	153B	—	1	36 (914)	60 (1524)	14 (356)	0.75 (19)	58.5 (1486)	34.5 (876)
	152H,152B	—	2	38 (965)	60 (1524)	17 (431)	33.88 (861)	1.75 (45)	61.69 (1567)
	152H	BP	2	38 (965)	60 (1524)	17 (431)	33.88 (861)	1.75 (45)	61.69 (1567)
	152H,152B,153H,153B	NB,NI	3	40 (1016)	84 (2134)	18 (457)	—	—	—
361	153H	—	1	36 (914)	51 (1295)	14 (356)	0.75 (19)	49.5 (1257)	34.5 (876)
		BP,NB	1	36 (914)	60 (1524)	14 (356)	0.75 (19)	58.5 (1486)	34.5 (876)
	153B	—	1	36 (914)	60 (1524)	14 (356)	0.75 (19)	58.5 (1486)	34.5 (876)
	152H,152B	—	2	38 (965)	60 (1524)	17 (431)	33.88 (861)	1.75 (45)	61.69 (1567)
	152H	BP	2	38 (965)	60 (1524)	17 (431)	33.88 (861)	1.75 (45)	61.69 (1567)
	152H,152B,153H,153B	NB,NI	3	40 (1016)	84 (2134)	18 (457)	—	—	—
480	153H	—	1	36 (914)	51 (1295)	14 (356)	0.75 (19)	49.5 (1257)	34.5 (876)
		BP	3♣	40 (1016)	84 (2134)	18 (457)	—	—	—
	152H,153B	Any	3	40 (1016)	84 (2134)	18 (457)	—	—	—
	152H	—	4♣	20 (508)	91.5 (2324)	20 (508)	—	—	—
	152H,152B	BP,NB	4♣	35 (889)	91.5 (2324)	20 (508)	—	—	—

★ Rating 20 Hp @208V, 25 Hp @240V, 50 Hp @ 480V, 60 Hp @ 600V

‡ Rating 25 Hp @208V, 30 Hp @240V, 60 Hp @ 480V, 75 Hp @ 600V

♣ 200 Hp @ 240V AC, 400 Hp @480V, 500 Hp @ 600V

## Important User Information

Read this document and the documents listed in the additional resources section about installation, configuration, and operation of this equipment before you install, configure, operate, or maintain this product. Users are required to familiarize themselves with installation and wiring instructions in addition to requirements of all applicable codes, laws, and standards.

Activities including installation, adjustments, putting into service, use, assembly, disassembly, and maintenance are required to be carried out by suitably trained personnel in accordance with applicable code of practice.

If this equipment is used in a manner not specified by the manufacturer, the protection provided by the equipment may be impaired.

In no event will Rockwell Automation, Inc. be responsible or liable for indirect or consequential damages resulting from the use or application of this equipment.

The examples and diagrams in this manual are included solely for illustrative purposes. Because of the many variables and requirements associated with any particular installation, Rockwell Automation, Inc. cannot assume responsibility or liability for actual use based on the examples and diagrams.

No patent liability is assumed by Rockwell Automation, Inc. with respect to use of information, circuits, equipment, or software described in this manual.

Reproduction of the contents of this manual, in whole or in part, without written permission of Rockwell Automation, Inc., is prohibited.

## Documentation Feedback

Your comments will help us serve your documentation needs better. If you have any suggestions on how to improve this document, complete this form, publication [RA-DU002](#), available at <http://www.rockwellautomation.com/literature/>.

Allen-Bradley, Rockwell Software, Rockwell Automation, and LISTEN. THINK. SOLVE are trademarks of Rockwell Automation, Inc.  
Trademarks not belonging to Rockwell Automation are property of their respective companies.

Rockwell Otomasyon Ticaret A.Ş., Kar Plaza İş Merkezi E Blok Kat:6 34752 İçerenköy, İstanbul, Tel: +90 (216) 5698400

**[www.rockwellautomation.com](http://www.rockwellautomation.com)**

---

### Power, Control and Information Solutions Headquarters

Americas: Rockwell Automation, 1201 South Second Street, Milwaukee, WI 53204-2496 USA, Tel: (1) 414.382.2000, Fax: (1) 414.382.4444  
Europe/Middle East/Africa: Rockwell Automation NV, Pegasus Park, De Kleetlaan 12a, 1831 Diegem, Belgium, Tel: (32) 2 663 0600, Fax: (32) 2 663 0640  
Asia Pacific: Rockwell Automation, Level 14, Core F, Cyberport 3, 100 Cyberport Road, Hong Kong, Tel: (852) 2887 4788, Fax: (852) 2508 1846